

CertainTeed Bufftech®

Vinyl Fence Installation Guidelines

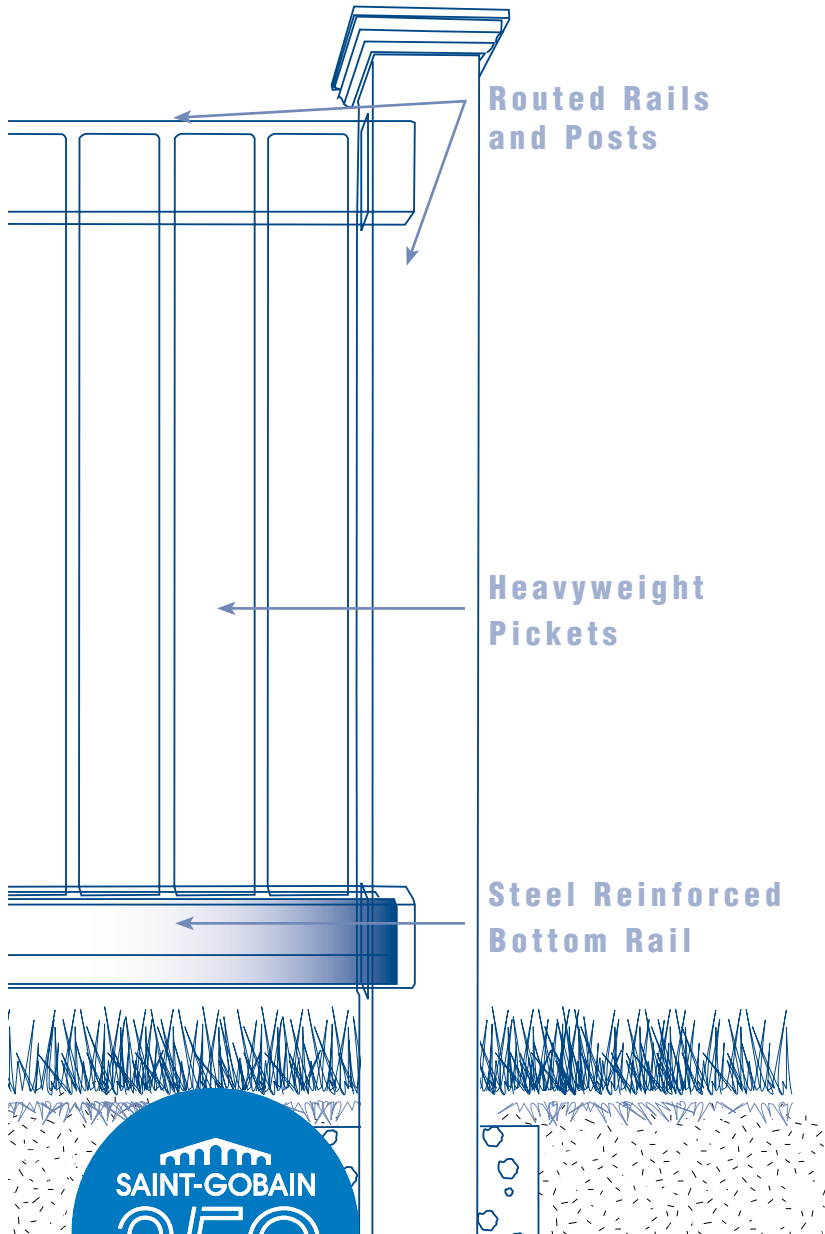

Table of Contents

System Components	2
Tools and Materials	3
General Information	4
Assembling Sections	
Traditional Picket Fence	
Cape Cod, Yorkshire	5-6
Danbury, Danbury with Select Cedar Texture, Rothbury	7-8
Contemporary Picket Fence	
Baron, Baron with Select Cedar Texture, Countess, Monarch, Princeton, Victorian	9-10
Classic Fence	
Manchester, Canterbury	11-12
Semi-Private Fence	
Columbia	13-14
Imperial, Imperial with Select Cedar Texture	15-16
Millbrook	17-18
Privacy Fence	
Chesterfield, Chesterfield with CertaGrain® Texture, Chesterfield with CertaStucco™ Texture	19-20
Chesterfield with Huntington Accent, Chesterfield with Westminster Accent	21-22
Galveston, Galveston with CertaGrain® Texture	23-24
New Lexington	25-26
Accent Fence	
Lattice, Victorian	27-28
Curved Rail	
Concave, Convex, "S" Curve and Swoop	29-30
Post & Rail Fence	
Crossbuck, 2-Rail, 3-Rail, 4-Rail	31-32
2-Rail, 3-Rail, 4-Rail with CertaGrain® Texture	33-34
Variable Terrain Installation	35-36
Post Routing Template Kit	37
Glossary	38



1665-2015

Fence System Components

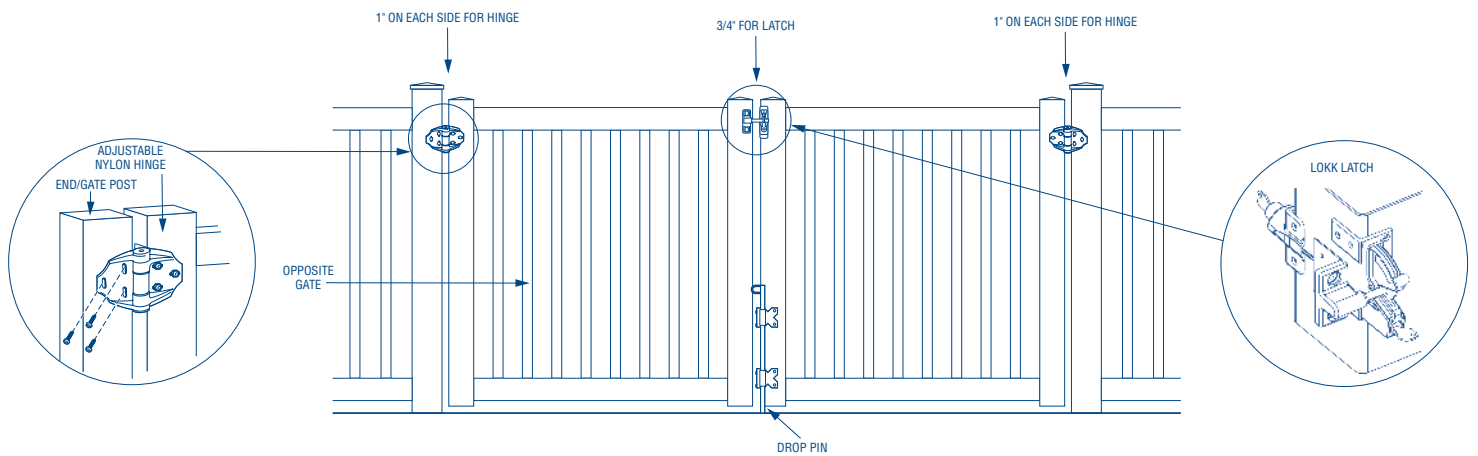
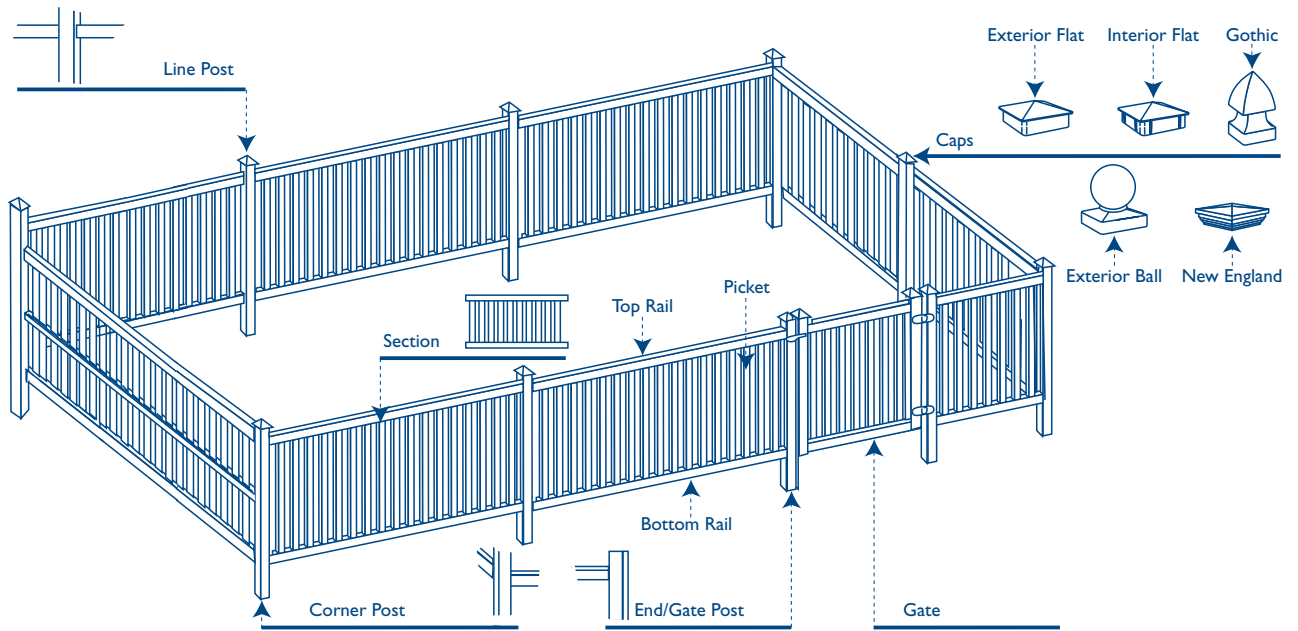

Tools and Materials

Getting Started

- Site plans and permits
- Measuring tape
- Hammer
- Wooden stakes
- String line
- Spray paint for hole centers for post and gate spacing
- Wooden spacer bar for post and gate spacing

Assembling Fence/Gates

- Drop cloth
- Hacksaw, circular saw or chop saw with masonry blade
- Square
- #3 square drive bit
- Phillips #2 screwdriver
- Drill and drill bits
 - 1/8" for #8 screws
 - 1/4" for bullet clips and drain holes
 - 5/32" for gate hardware if using aluminum insert
 - 3/8" for lock rings
- 1/2" deep socket (or nut driver) for traditional picket

Digging Holes

- Post hole digging tools
 - Shovel
 - Post hole digger
 - 10" auger for 4x4 posts
 - 12" auger for 5x5 posts

Installing Post

- Wheelbarrow
- Concrete mixing tools
- Short length of wood, 2x4 for tamping concrete
- Garden hose
- Level
- Template kit with router
- Spiral saw

Installing Bottom Rail

- Leveling blocks
- Shim stock
- Duct tape to seal rail ends

Installing Gate(s)

- Wrench
 - 7/16" for hinge nuts
- Flat screwdriver to activate hinge spring

Filling Post with Concrete

- Rubber mallet to tamp post
- Funnel for filling post
- Ladder for high fences

Cleaning Up

- Abrasive-type pad
- Bucket and sponge

Additional Tools - Installing on Concrete

- 1/2" masonry drill
- Core drill

Additional Tools - EZ Set Brackets

- 7/16" wrench

General Information

(Be sure to call underground prior to digging)

Installation techniques may vary in different regions; be sure to check local requirements prior to installation.

Concrete Requirements

All posts require concrete to be poured around the post base. All hinge and latch posts require concrete to fill the post inside, enough to cover the rebar and gate hardware (or insertion of the aluminum gate post stiffener).

- Avoid “soupy” concrete mix as it will make concrete weak

Concrete Usage for Posts				
Post Size	Fence Height	End Line or Corner Posts	End Posts Filled with Concrete	Gate Posts
4x4	3'	100 lbs	145 lbs	160 lbs
4x4	4'	100 lbs	155 lbs	175 lbs
5x5	5'	140 lbs	235 lbs	270 lbs
5x5	6'	140 lbs	240 lbs	285 lbs
5x5	2 rail	140 lbs	210 lbs	240 lbs
5x5	3 rail	140 lbs	230 lbs	260 lbs
5x5	4 rail	140 lbs	250 lbs	280 lbs

Note: Determine total pounds of concrete required based on number of posts required. Divide by 60 or 80 lb. bag.
Figures based on 4x4 hole=10", 5x5 hole=12", both 30" deep.

- Check local codes for frost line depth and regulations

Solidify Posts

Gate hinge and latch posts as well as end posts can be solidified by using an aluminum gate post stiffener inside each post or by filling post with concrete and rebar.*

Rebar Separator Clips (for use with rebar and concrete method)

Use 2 clips for each post. Position clips on the rebar approximately 6" down from top and 6" up from bottom. Clips are located in gate hardware box.

Alternative Fence Installations

For fence systems on concrete, use steel posts. On concrete applications fence may be installed with 1-5/8" (4 x 4 post) or 1-7/8" (5 x 5 post) galvanized steel post set in hydraulic cement. EZ Set bracket bolts to post as a spacer.

For wall mounting, use wall mount brackets.

EZ Set Bracket Installation Instructions on Concrete

- Core drill hole into concrete
- Minimum 4" deep
- Post centers will remain the same as normal installation
- Rails will have to be cut down to fit between steel post
- Fill hole with hydraulic cement. Insert steel post
 - For 4" vinyl post, set 1 5/8" OD steel post
 - For 5" vinyl post, set 1-7/8" OD steel post

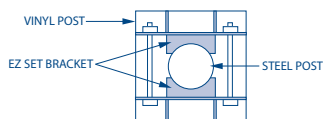

- Steel post should go at least halfway up the vinyl post
- Put EZ Set brackets together and slide over steel post
- Place one bracket on steel post below where the routed hole will be on your vinyl post
- Place other bracket just below the top of your steel post
- Slide vinyl post over steel post with EZ Set brackets

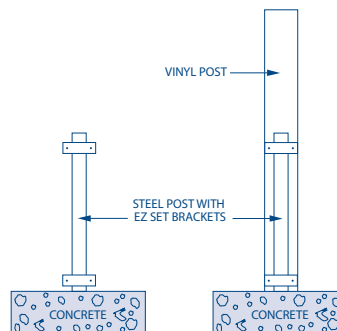

Care of the Product

- Place vinyl fence components on a non-abrasive surface, such as a drop cloth, to avoid scratching
- Protect components during transportation to your installation site to avoid damage
- Avoid excessive force when assembling components
- Avoid overtightening screws
- Clean vinyl fence with mild detergent and a plastic scouring pad. For more stubborn stains, use a cleanser such as Soft Scrub® or cleaning solution listed on warranty
- Concrete is easily washed off when wet, but can also be removed when dry

Gates

- Specific gate hardware instructions included with individual components
- Gate(s) must be assembled prior to fence to accurately establish space between hinge and latch posts and height of fence
- Gate requires 2" clearance under bottom rail on level ground
- When building gates in the field, ensure that 1/4" drain holes are drilled in bottom rail
- Determine gate swing direction to assist in ground clearance and positioning
- Steel channel not required in bottom rail of gate

* Caution – In climates that experience freeze-thaw cycles, this installation method could result in post cracking over time. This would not be covered by the warranty.

Traditional Picket Fence – Cape Cod, Yorkshire

1. Getting Started

- Be sure to call underground prior to digging
- Assemble gates (if necessary) and decide where they will be located
- Stake out the fence line
- Space and mark post hole locations for gate and sections (spacer bar/template may be useful)
- Start at gate end post and work outward to determine proper fence height relative to ground

2. Dig Holes

- Dig holes 30" deep or to frost line
 - Hole size for 5 x 5 posts = approximately 12"
 - Hole size for 4 x 4 posts = approximately 10"
- Clean holes and check for straight walls

3. Install First Post

- Insert post in hole
- Determine rough height
- Fill hole around post with concrete mix (sand, gravel and cement) approximately 2" or 4" below grade
- Tamp concrete in hole to eliminate air pockets
- Level and square post

4. Install Bottom Rail

- Tape the ends of any rail being inserted into a post that is to be filled with concrete to prevent concrete seepage
- Insert rail into post
 - Note: Pickets will attach to rail on the side with the small (1/4") holes
- Insert lock ring in end of rail
- Depress lock ring tabs and insert rail in post
- Tabs will recoil to hold rail in post

5. Install Second Post

- Insert second post in hole
- Insert bottom rail in post
- Insert block under bottom rail to position at correct fence height
- Fill hole around second post with concrete mix
- Tamp, level and square fence
- Assembly may be continued by installing all bottom rails first, or one section at a time

6. Support and Secure

- Level and square fence
- To lower a post, place a wood block from corner to corner on the post and carefully tap with a mallet
- Never strike the PVC post without a wood support

7. Install Pickets and Rails

- Insert top rail in post
- Depress lock ring tabs, insert top rail in post

8. Install Pickets

- For field assembly, insert hex washer head screw through large (3/4") pre-drilled hole in top rail
- Align pre-drilled hole in picket, tighten with 1/2" deep socket wrench or nut driver with clutchdrill (do not overtighten)
- Repeat for bottom rail
- Insert (3/4") hole plug into hole in back side of rail

9. Secure Rails

- Square pickets and rails
- Check for even picket spacing on each end of rail
- Top rail may be secured inside post with a #8 x 3/4" screw on each end

10. Hang Gate/Install Hardware

- For complete details, see gate installation instructions in hardware box
- Position gate between posts
- Allow 1" gap for hinge and 3/4" for latch and gate swing
- Block up gate to square with fence; rails should be level
- Gate hardware must be mounted to two sides of the post

11. Solidify Gate Posts

- It is critical that gate hinge and latch posts are solid to ensure proper gate functionality. Two methods are available:
 - A. Aluminum gate post stiffener
 - Slide aluminum gate stiffener inside hinge, latch or end posts with open end facing routed hole
 - Drive a screw through the vinyl into the aluminum stiffener at the bottom of the post to hold in place
 - Insert post into ground
 - Fill hole with concrete around outside of post
 - B. Concrete and rebar*
 - Use two pieces of 1/2" rebar in each hinge, latch and end post
 - Rebar should extend from the bottom of the hole to approximately 12" from the top of the post
 - Hold rebar in opposite corners of post with rebar separator clips
 - Fill post with concrete mix to cover rebar and hardware fasteners
 - Tamp post with a rubber mallet to eliminate air pockets
 - Leave gate on blocks for 72 hours to allow concrete to set

12. Install Caps

- Install post caps
- Caps may be secured with glue, silicone adhesive or #8 x 3/4" screws, caps and washers

* Caution – In climates that experience freeze-thaw cycles, this installation method could result in post cracking over time. This would not be covered by the warranty.

Traditional Picket Fence

Includes: Cape Cod, Yorkshire

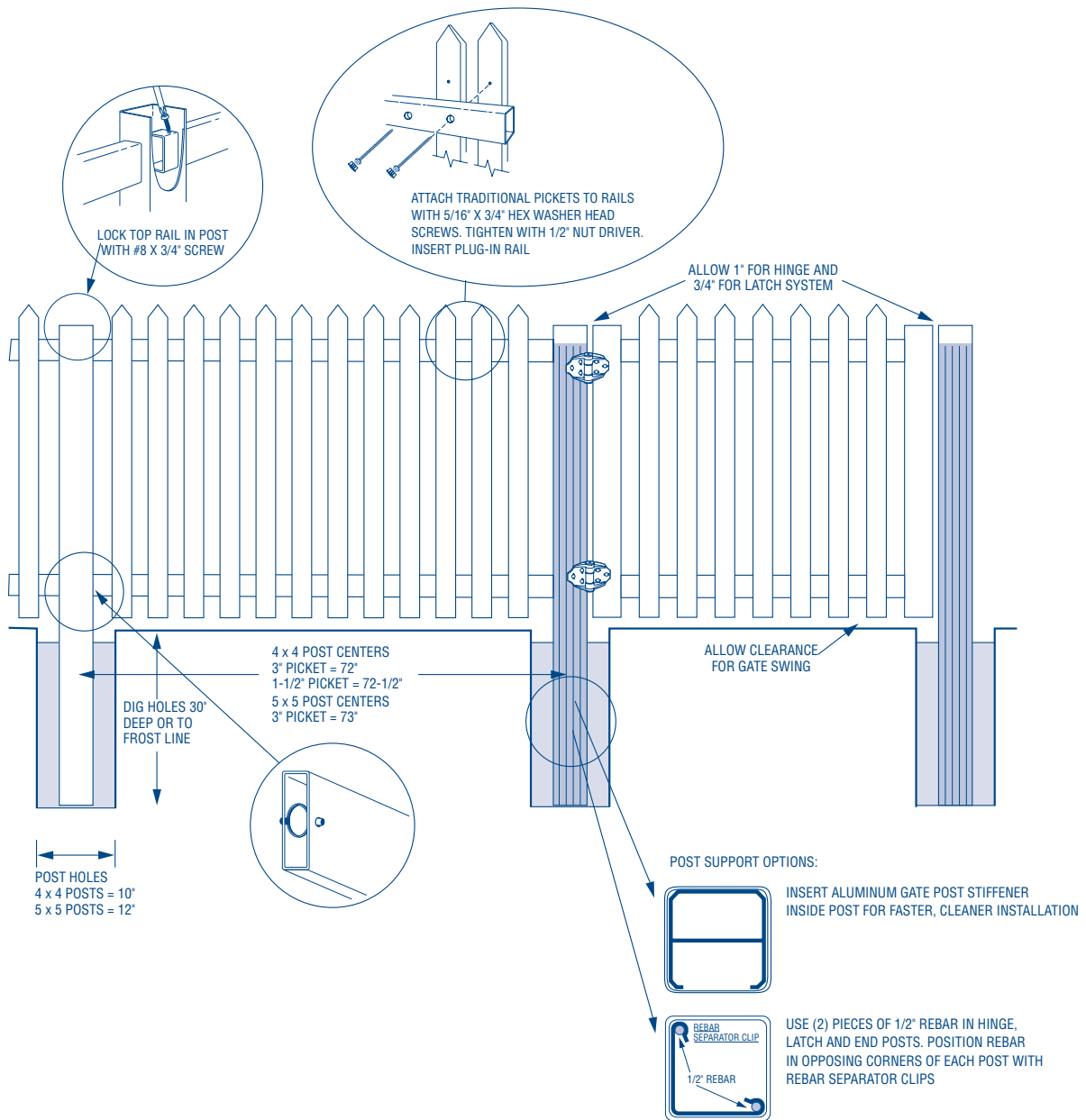

Traditional Picket Fence – Danbury (straight & concave), Danbury with Select Cedar Texture (straight & concave), Rothbury (straight & concave)

1. Getting Started

- Be sure to call underground prior to digging
- Assemble gates (if necessary) and decide where they will be located
- Stake out the fence line
- Space and mark post hole locations for gate and sections (spacer bar/template may be useful)
- Start at gate end post and work outward to determine proper fence height relative to ground

2. Dig Holes

- Dig holes 30" deep or to frost line
 - Hole size for 4 x 4 posts = approximately 10"
- Clean holes and check for straight walls

3. Install First Post

- Insert post in hole
- Determine rough height
- Fill hole around post with concrete mix (sand, gravel and cement) approximately 2" or 4" below grade
- Tamp concrete in hole to eliminate air pockets
- Level and square post

4. Install Bottom Rail

- Check bottom rail for drain holes
- Tape the ends of any rail being inserted into a post that is to be filled with concrete to prevent concrete seepage
- Insert lock ring in end of rail
- Depress lock ring tabs and insert rail in post
- Tabs will recoil to hold rail in post

5. Install Second Post

- Insert second post in hole
- Insert bottom rail in post
- Insert block under bottom rail to position at correct fence height
- Fill hole around second post with concrete mix
- Tamp, level and square fence
- Assembly may be continued by installing all bottom rails first, or one section at a time

6. Support and Secure

- Level and square fence
- To lower a post, place a wood block from corner to corner on the post and carefully tap with a mallet
- Never strike the PVC post without a wood support

7. Install Pickets

- Insert top rail in post with large holes facing down
- Insert pickets through holes in top rail
- Insert pickets in bottom rail. Pickets are crimped to hold in rail

8. Secure Rails

- Depress lock ring tabs, insert top rail in post
- Square pickets and rails
- Check for even picket spacing on each end of rail
- Top rail may be secured inside post with a #8 x 3/4" screw on each end

9. Hang Gate/Install Hardware

- For complete details, see gate installation instructions in hardware box
- Position gate between posts
- Allow 1" gap for hinge and 3/4" for latch and gate swing
- Block up gate to square with fence; rails should be level
- Gate hardware must be mounted to two sides of the post

10. Solidify Gate Posts

- It is critical that gate hinge and latch posts are solid to ensure proper gate functionality. Two methods are available:
 - A. Aluminum gate post stiffener
 - Slide aluminum gate stiffener inside hinge, latch or end posts with open end facing routed hole
 - Drive a screw through the vinyl into the aluminum stiffener at the bottom of the post to hold in place
 - Insert post into ground
 - Fill hole with concrete around outside of post
 - B. Concrete and rebar*
 - Use two pieces of 1/2" rebar in each hinge, latch and end post
 - Rebar should extend from the bottom of the hole to approximately 12" from the top of the post
 - Hold rebar in opposite corners of post with rebar separator clips
 - Fill post with concrete mix to cover rebar and hardware fasteners
 - Tamp post with a rubber mallet to eliminate air pockets
 - Leave gate on blocks for 72 hours to allow concrete to set

11. Install Caps

- Install post caps
- Caps may be secured with glue, silicone adhesive or #8 x 3/4" screws, caps and washers

Traditional Picket Fence

- Includes: Danbury (straight & concave)
- Danbury with Select Cedar Texture (straight & concave)
- Rothbury (straight & concave)

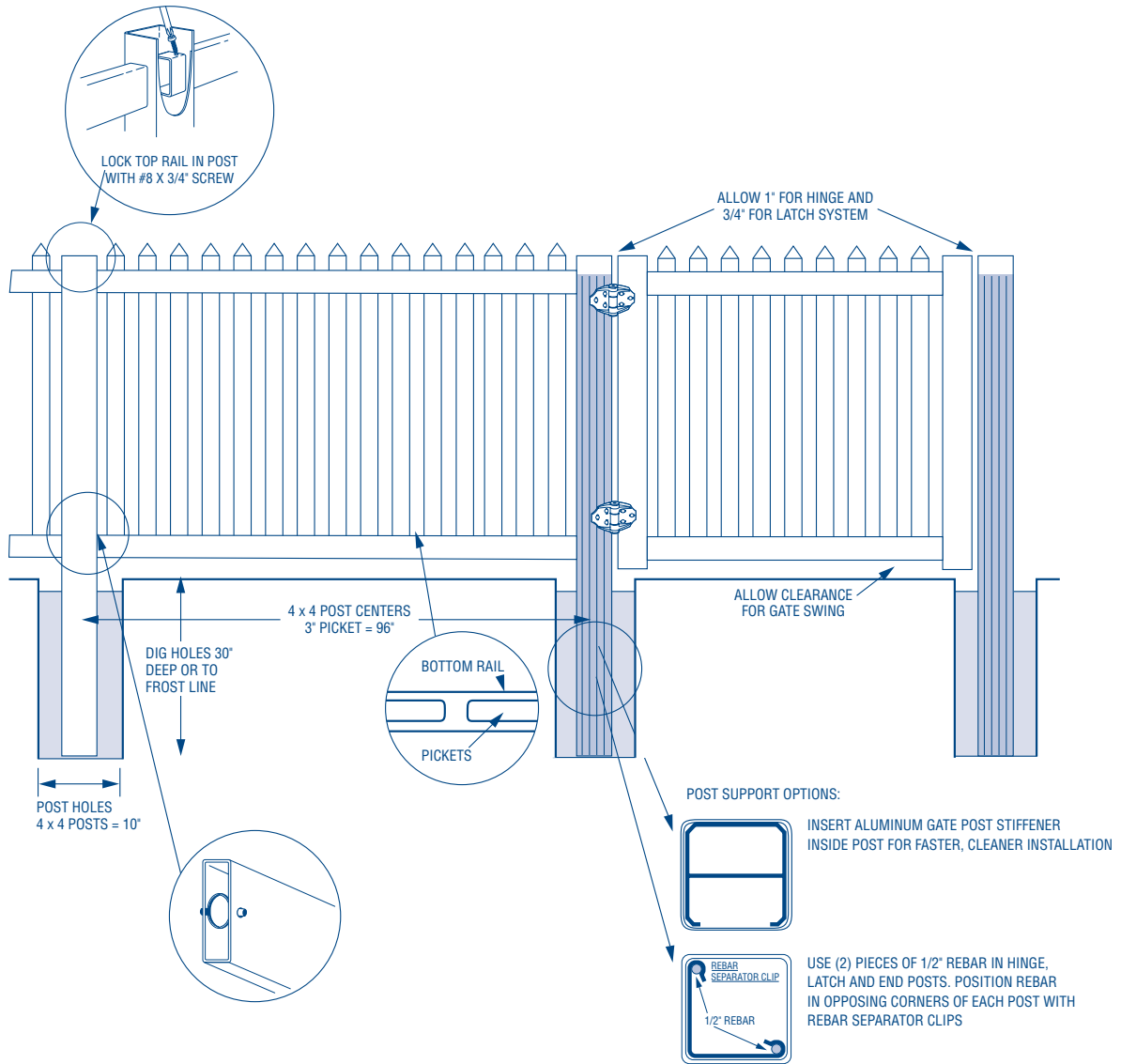

Contemporary Picket Fence – Baron, Baron with Select Cedar Texture, Countess, Monarch, Princeton, Victorian

1. Getting Started

- Be sure to call underground prior to digging
- Assemble gates (if necessary) and decide where they will be located
- Stake out the fence line
- Space and mark post hole locations for gate and sections (spacer bar/template may be useful)
- Start at gate end post and work outward to determine proper fence height relative to ground

2. Dig Holes

- Dig holes 30" deep or to frost line
 - Hole size for 5 x 5 posts = approximately 12"
 - Hole size for 4 x 4 posts = approximately 10"
- Clean holes and check for straight walls

3. Install First Post

- Insert post in hole
- Determine rough height
- Fill hole around post with concrete mix (sand, gravel and cement) approximately 2" or 4" below grade
- Tamp concrete in hole to eliminate air pockets
- Level and square post

4. Install Bottom Rail

- Check bottom rail for drain holes
- Tape the ends of any rail being inserted into a post that is to be filled with concrete to prevent concrete seepage
- Insert lock ring in end of rail
- Depress lock ring tabs and insert rail in post
- Tabs will recoil to hold rail in post

5. Install Second Post

- Insert second post in hole
- Insert bottom rail in post
- Insert block under bottom rail to position at correct fence height
- Fill hole around second post with concrete mix
- Tamp, level and square fence
- Assembly may be continued by installing all bottom rails first, or one section at a time

6. Support and Secure

- Level and square fence
- To lower a post, place a wood block from corner to corner on the post and carefully tap with a mallet
- Never strike the PVC post without a wood support

7. Install Pickets and Rails

- Insert mid-rail (if applicable) in post with large holes facing down
- Insert pickets through holes in mid-rail
- Insert pickets in bottom rail. Temporarily remove mid-rail ends from post. Insert top rail over pickets
- Insert mid-rail and top rail in post

8. Secure Rails

- Depress lock ring tabs, insert top rail in post
- Square pickets and rails
- Check for even picket spacing on each end of rail
- Secure rail inside post with a #8 x 3/4" screw (do this on both ends)
- Level mid-rail, secure rail to pickets with (2) #8 x 1-1/2" screws, snap caps and washers evenly spaced along rail

9. Hang Gate/Install Hardware

- For complete details, see gate installation instructions in hardware box
- Position gate between posts
- Allow 1" gap for hinge and 3/4" for latch and gate swing
- Block up gate to square with fence; rails should be level
- Gate hardware must be mounted to two sides of the post

10. Solidify Gate Posts

- It is critical that gate hinge and latch posts are solid to ensure proper gate functionality. Two methods are available:
 - A. Aluminum gate post stiffener
 - Slide aluminum gate stiffener inside hinge, latch or end posts with open end facing routed hole
 - Drive a screw through the vinyl into the aluminum stiffener at the bottom of the post to hold in place
 - Insert post into ground
 - Fill hole with concrete around outside of post
 - B. Concrete and rebar*
 - Use two pieces of 1/2" rebar in each hinge, latch and end post
 - Rebar should extend from the bottom of the hole to approximately 12" from the top of the post
 - Hold rebar in opposite corners of post with rebar separator clips
 - Fill post with concrete mix to cover rebar and hardware fasteners
 - Tamp post with a rubber mallet to eliminate air pockets
 - Leave gate on blocks for 72 hours to allow concrete to set

11. Install Caps

- Install post caps
- Caps may be secured with glue, silicone adhesive or #8 x 3/4" screws, caps and washers

* Caution – In climates that experience freeze-thaw cycles, this installation method could result in post cracking over time. This would not be covered by the warranty.

Contemporary Picket Fence

Includes: Baron, Baron with Select Cedar Texture, Countess, Monarch, Princeton, Victorian

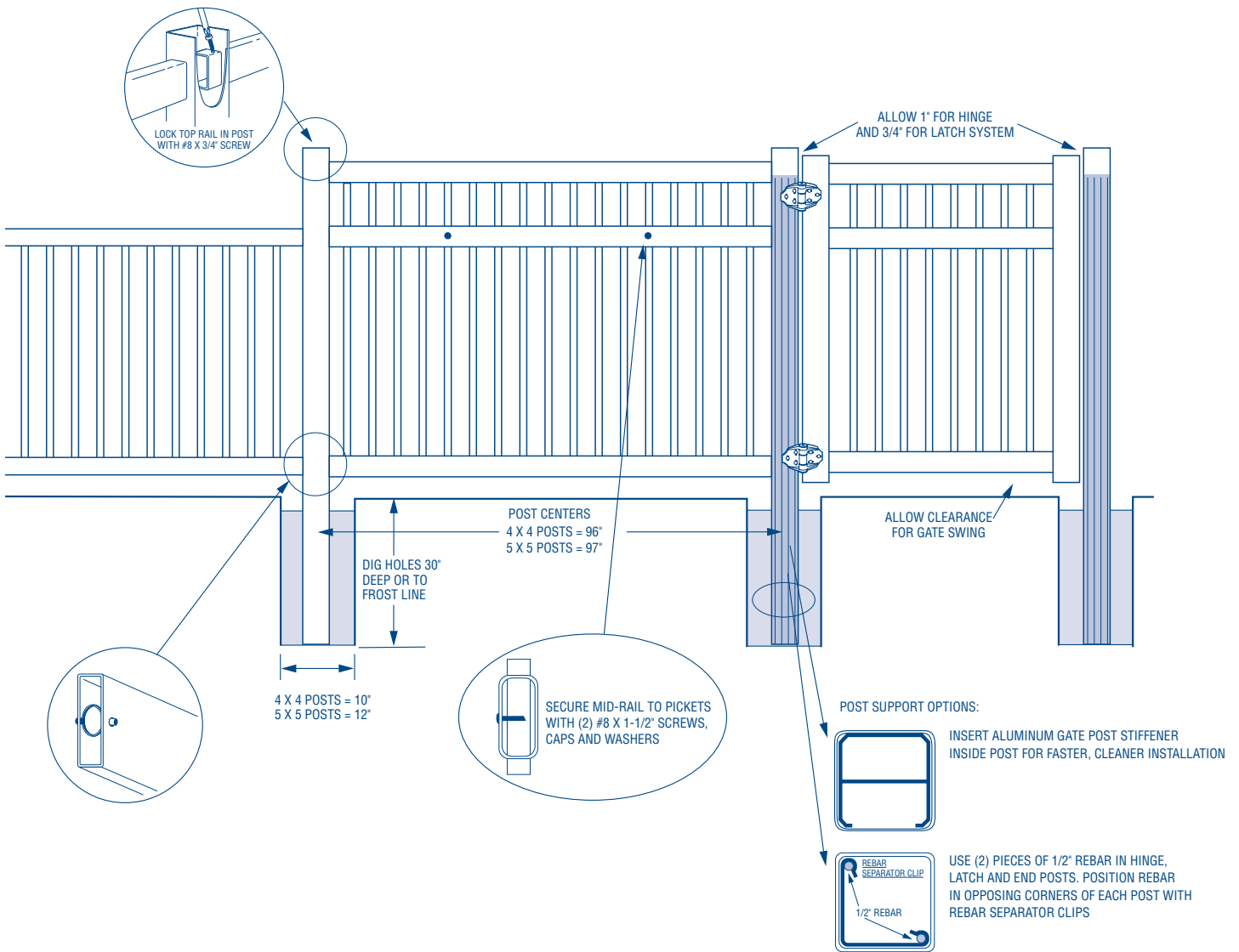

Classic Fence – Manchester (straight & concave), Canterbury (straight & swoop)

1. Getting Started

- Be sure to call underground prior to digging
- Assemble gates (if necessary) and decide where they will be located
- Stake out the fence line
- Space and mark post hole locations for gate and sections (spacer bar/template may be useful)
- Start at gate end post and work outward to determine proper fence height relative to ground

2. Dig Holes

- Dig holes 30" deep or to frost line
 - Hole size for 5 x 5 posts = approximately 12"
- Clean holes and check for straight walls

3. Install First Post

- Insert post in hole
- Determine rough height
- Fill hole around post with concrete mix (sand, gravel and cement) approximately 2" or 4" below grade
- Tamp concrete in hole to eliminate air pockets
- Level and square post

4. Install Bottom Rail

- Tape the ends of any rail being inserted into a post that is to be filled with concrete to prevent concrete seepage
- Insert lock ring in each end of rail
- Depress lock ring tabs and insert rail in post. Tabs will recoil to hold rail in post

5. Install Second Post

- Insert second post in hole
- Insert bottom rail in post
- Insert block under bottom rail to position at correct fence height
- Fill hole around second post with concrete mix
- Tamp, level and square fence
- Assembly may be continued by installing all bottom rails first, or one section at a time

6. Support and Secure

- Level and square fence
- To lower a post, place a wood block from corner to corner on the post and carefully tap with a mallet
- Never strike the PVC post without a wood support

7. Install Rails & Pickets

- Middle and upper rails are routed with larger holes on the bottom for ease of installation and racking
- For Canterbury – Install mid-rail. Depress lock ring and insert rail into post. Insert short pickets into every second hole starting with the end hole. Pickets are factory crimped to hold in rail. Install top rail, and insert longer pickets into remaining holes

- For Manchester - Depress lock ring and insert top rail in post. Pickets are factory crimped to hold in rail. Insert pickets through rail into bottom rail
- For Manchester Concave - 8 longer pickets are supplied for in-field design and cutting
- Field cut pickets should be cut to size and then crimped, or drill a 1/4" hole in one side, 1" from the bottom
- Install bullet clip in hole and insert picket into rail
- For Canterbury Swoop - All long pickets need to be field cut. Measure from cap and cut off crimped end. Picket lengths are:

#1	31-7/8"	#8	38"
#2	32-3/4"	#9	38-7/8"
#3	33-5/8"	#10	39-3/4"
#4	34-1/2"	#11	40-5/8"
#5	35-3/8"	#12	41-1/2"
#6	36-1/4"	#13	42-3/8"
#7	37-1/8"	#14	43-1/2"

8. Hang Gate/Install Hardware

- For complete details, see gate installation instructions in hardware box
- Position gate between posts
- Allow 1" gap for hinge and 3/4" for latch and gate swing
- Block up gate to square with fence; rails should be level
- Gate hardware must be mounted to two sides of the post

9. Solidify Gate Posts

- It is critical that gate hinge and latch posts are solid to ensure proper gate functionality. Two methods are available:
 - A. Aluminum gate post stiffener
 - Slide aluminum gate stiffener inside hinge, latch or end posts with open end facing routed hole
 - Drive a screw through the vinyl into the aluminum stiffener at the bottom of the post
 - Insert post into the ground
 - Fill hole with concrete around outside of post
 - B. Concrete and rebar*
 - Use two pieces of 1/2" rebar in each hinge, latch and end post
 - Rebar should extend from the bottom of the hole to approximately 12" from the top of the post
 - Hold rebar in opposite corners of post with rebar separator clips
 - Fill post with concrete mix to cover rebar and hardware fasteners
 - Tamp post with a rubber mallet to eliminate air pockets
 - Leave gate on blocks for 72 hours to allow concrete to set

10. Install Caps

- Install post caps
- Caps may be secured with glue, silicone adhesive or #8 x 1-1/2" screws, caps and washers

* Caution – In climates that experience freeze-thaw cycles, this installation method could result in post cracking over time. This would not be covered by the warranty.

Classic Fence

Includes: Manchester (straight & concave)
 Canterbury (straight & sloop)

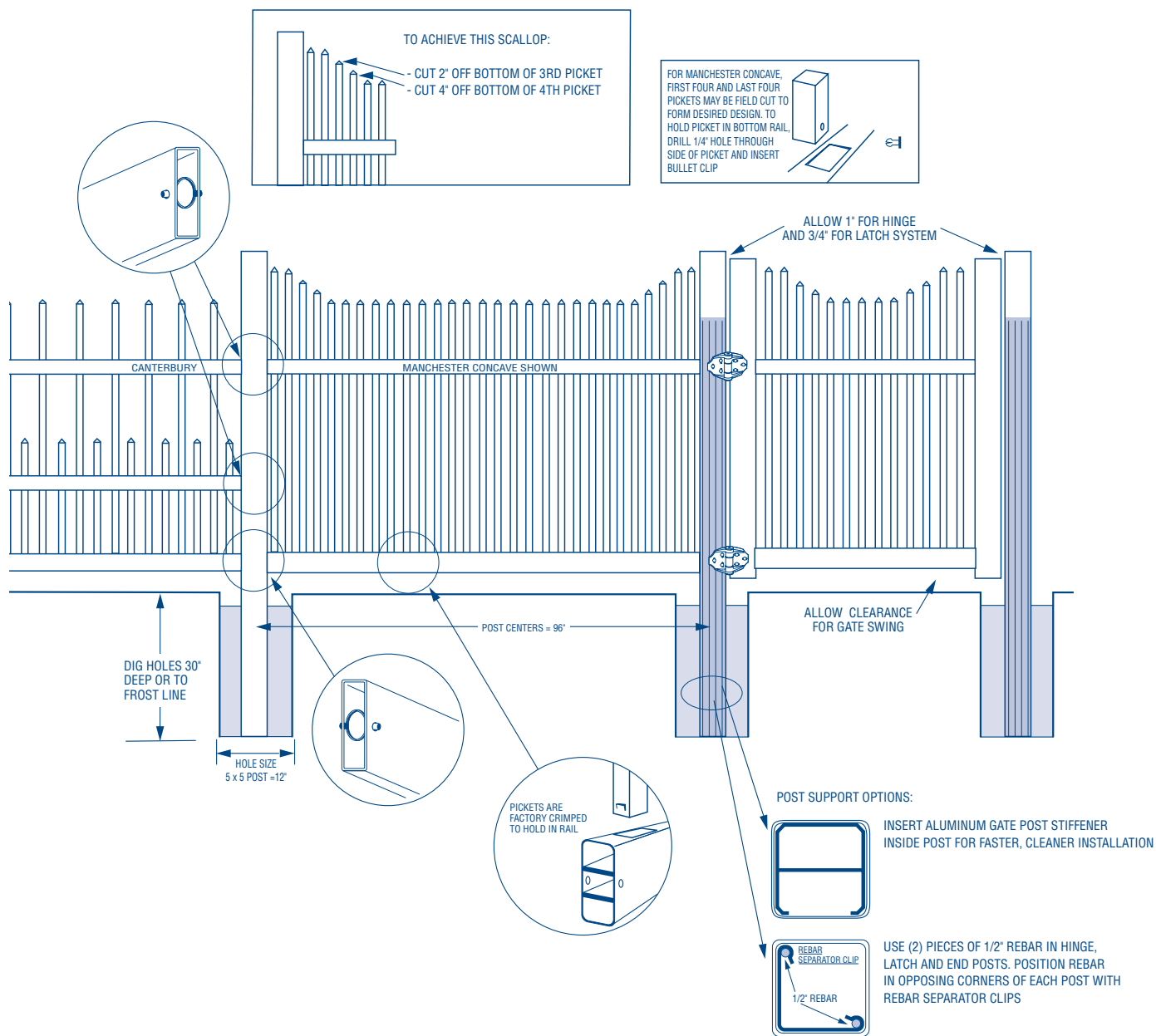

Semi-Private Fence – Columbia

1. Getting Started

- Be sure to call underground prior to digging
- Assemble gates (if necessary) and decide where they will be located
- Stake out the fence line
- Space and mark post hole locations for gate and sections (spacer bar/template may be useful)
- Start at gate end post and work outward to determine proper fence height relative to ground

2. Dig Holes

- Dig holes 30" deep or to frost line
 - Hole size for 5 x 5 posts = approximately 12"
- Clean holes and check for straight walls

3. Install First Post

- Insert post in hole
- Determine rough height
- Fill hole around post with concrete mix (sand, gravel and cement) approximately 2" or 4" below grade
- Tamp concrete in hole to eliminate air pockets
- Level and square post

4. Install Bottom Rail

- Tape the ends of any rail going into a post that is to be filled with concrete to prevent concrete seepage
- Depress bullet clip and insert bottom rail in post; clip will drop down to hold rail in post

5. Install Second Post

- Insert second post in hole
- Insert bottom rail in post
- Insert block under bottom rail to position at correct fence height
- Fill hole around second post with concrete mix
- Tamp, level and square fence
- Assembly may be continued by installing all bottom rails first, or one section at a time

6. Support and Secure

- Level and square fence
- To lower a post, place a wood block from corner to corner on the post and carefully tap with a mallet
- Never strike the PVC post without a wood support

7. Install Mid-Rail

- Insert mid-rail in first post with larger routed holes facing in the down position
- Insert into second post (Note: This rail floats in post. No bullet clips are required)

8. Install Pickets and Top Rail

- Insert all pickets through mid-rail into bottom rail
- Temporarily remove mid-rail ends from post and pull the section forward
- Insert the top rail over the pickets starting at one end
- Insert the mid-rail and the top rail back into the posts
- Secure top rail inside post with a #8 x 3/4" screw

9. Hang Gate/Install Hardware

- For complete details, see gate installation instructions in hardware box
- Position gate between posts
- Allow 1" gap for the hinge and 3/4" for latch and gate swing
- Block up gate to square with fence; rails should be level
- Gate hardware must be mounted to two sides of the post

10. Solidify Gate Posts

- It is critical that gate hinge and latch posts are solid to ensure proper gate functionality. Two methods are available:
 - A. Aluminum gate post stiffener
 - Slide aluminum gate stiffener inside hinge, latch or end posts with open end facing routed hole
 - Drive a screw through the vinyl into the aluminum stiffener at the bottom of the post
 - Insert post into the ground
 - Fill hole with concrete around outside of post
 - B. Concrete and rebar*
 - Use two pieces of 1/2" rebar in each hinge, latch and end post
 - Rebar should extend from the bottom of the hole to approximately 12" from the top of the post
 - Hold rebar in opposite corners of post with rebar separator clips
 - Fill post with concrete mix to cover rebar and hardware fasteners
 - Tamp post with a rubber mallet to eliminate air pockets
 - Leave gate on blocks for 72 hours to allow concrete to set

11. Install Caps

- Install post caps
- Caps may be secured with glue, silicone adhesive or #8 x 3/4" screws, caps and washers

For accents, see pages 27 and 28

Semi-Private Fence

Includes: Columbia

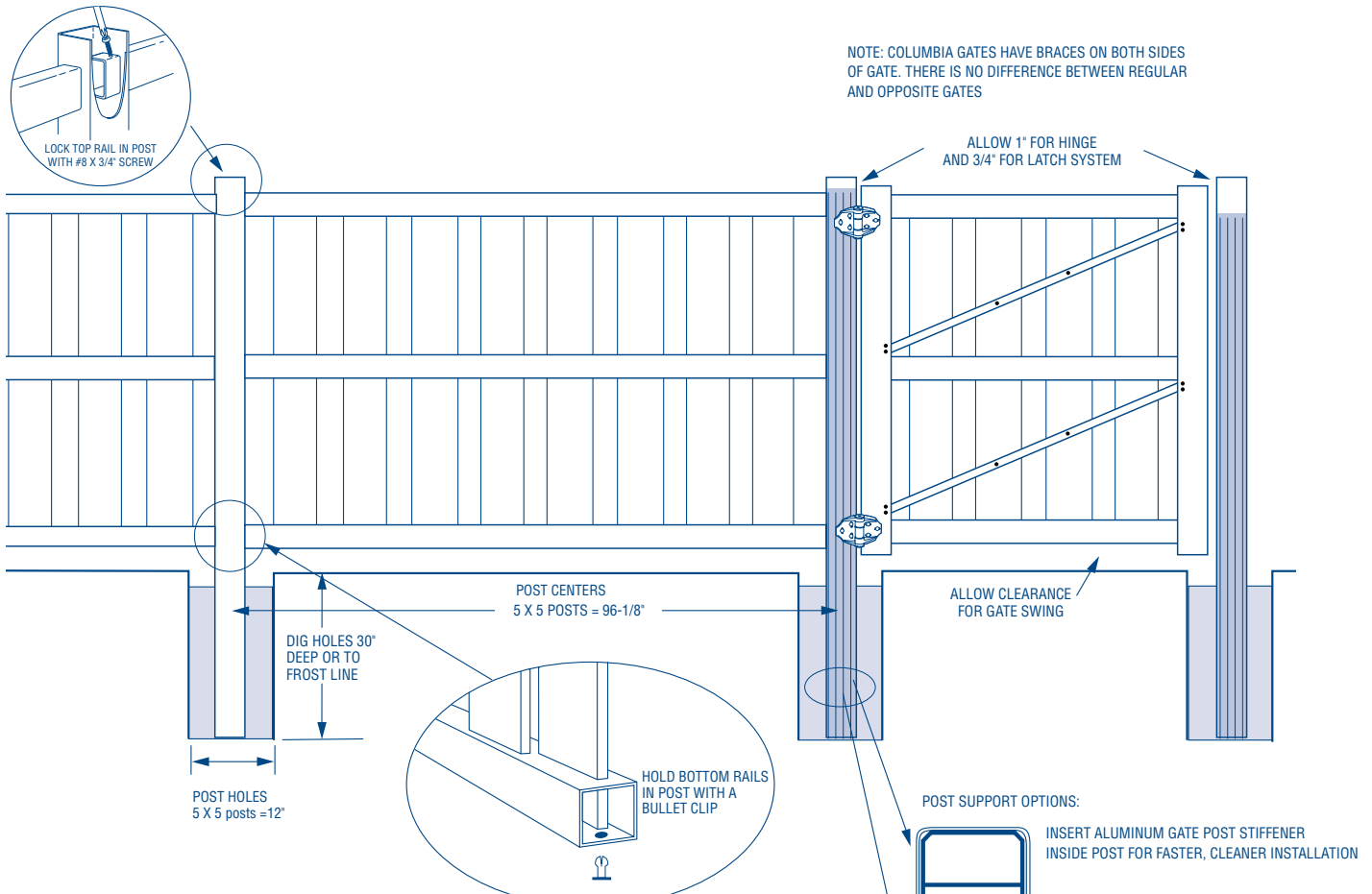

EMBEDMENT DETAIL FOR OPTIONAL LINE POST STIFFENER ALUMINUM INSERT

MINIMUM 48" INSERT REQUIRED TO COMPLY WITH THE HIGH VELOCITY HURRICANE ZONES SECTION R44003.1.2.1 OF THE FLORIDA BUILDING CODE

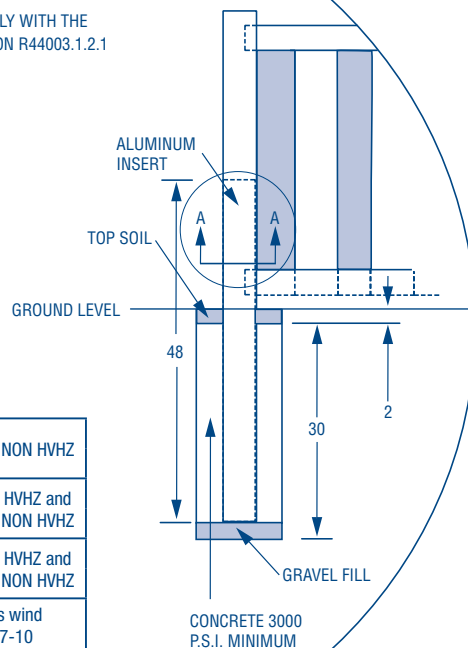
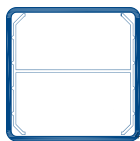

MAXIMUM POST SPACING AND FOOTING DIMENSIONS

Wind Exposure	Footing Depth	Max. Post Spacing	
B	30"	97"	NON HVHZ
B	24"	66"	
C	36"	88"	HVHZ and NON HVHZ
C	30"	68"	
D	36"	75"	HVHZ and NON HVHZ
D	30"	56"	

HVHZ: Miami-Dade and Broward counties wind exposures as defined in the ASCE 7-10



FEATURING WINDZONE™ PERFORMANCE

Semi-Private Fence – Imperial, Imperial with Select Cedar Texture

1. Getting Started

- Be sure to call underground prior to digging
- Assemble gates (if necessary) and decide where they will be located
- Stake out the fence line
- Space and mark post hole locations for gate and sections (spacer bar/template may be useful)
- Start at gate end post and work outward to determine proper fence height relative to ground

2. Dig Holes

- Dig holes 30" deep or to frost line
 - Hole size for 5 x 5 posts = approximately 12"
 - Hole size for 4 x 4 posts = approximately 10"
- Clean holes and check for straight walls

3. Install First Post

- Insert post in hole
- Determine rough height
- Fill hole around post with concrete mix (sand, gravel and cement) approximately 2" or 4" below grade
- Tamp concrete in hole to eliminate air pockets
- Level and square post

4. Install Bottom Rail

- Check bottom rail for drain holes
- Tape the ends of any rail being inserted into a post that is to be filled with concrete to prevent concrete seepage
- Insert lock ring in end of rail
- Depress lock ring tabs and insert rail in post
- Tabs will recoil to hold rail in post

5. Install Second Post

- Insert second post in hole
- Insert bottom rail in post
- Insert block under bottom rail to position at correct fence height
- Fill hole around second post with concrete mix
- Tamp, level and square fence
- Fence assembly may be continued by installing all bottom rails first, or one section at a time

6. Support and Secure

- Level and square fence
- To lower a post, place a wood block from corner to corner on the post and carefully tap with a mallet
- Never strike the PVC post without a wood support

7. Install Pickets and Rails

- Insert mid-rail (if applicable) in post with large holes facing down
- Insert pickets through holes in mid-rail
- Insert pickets in bottom rail. Temporarily remove middle rail ends from post. Insert top rail over pickets
- Insert mid-rail and top rail in post

8. Secure Rails

- Depress lock ring tabs, insert top rail in post
- Square pickets and rails
- Check for even picket spacing on each end of rail
- Secure rail inside post with a #8 x 3/4" screw (do this on both ends)
- Level mid-rail, secure rail to pickets with (2) #8 x 1-1/2" screws, snap caps and washers evenly spaced along rail

9. Hang Gate/Install Hardware

- For complete details, see gate installation instructions in hardware box
- Position gate between posts
- Allow 1" gap for hinge and 3/4" for latch and gate swing
- Block up gate to square with fence; rails should be level
- Gate hardware must be mounted to two sides of the post

10. Solidify Gate Posts

- It is critical that gate hinge and latch posts are solid to ensure proper gate functionality. Two methods are available:
 - A. Aluminum gate post stiffener
 - Slide aluminum gate stiffener inside hinge, latch or end posts
 - Drive a screw through the vinyl into the aluminum stiffener at the bottom of the post
 - Insert post into the ground
 - Fill hole with concrete around outside of post
 - B. Concrete and rebar*
 - Use two pieces of 1/2" rebar in each hinge, latch and end post
 - Rebar should extend from the bottom of the hole to approximately 12" from the top of the post
 - Hold rebar in opposite corners of post with rebar separator clips
 - Fill post with concrete mix to cover rebar and hardware fasteners
 - Tamp post with a rubber mallet to eliminate air pockets
 - Leave gate on blocks for 72 hours to allow concrete to set

11. Install Caps

- Install post caps
- Caps may be secured with glue, silicone adhesive or #8 x 3/4" screws, caps and washers

* Caution – In climates that experience freeze-thaw cycles, this installation method could result in post cracking over time. This would not be covered by the warranty.

Semi-Private Fence

Includes: Imperial, Imperial with Select Cedar Texture

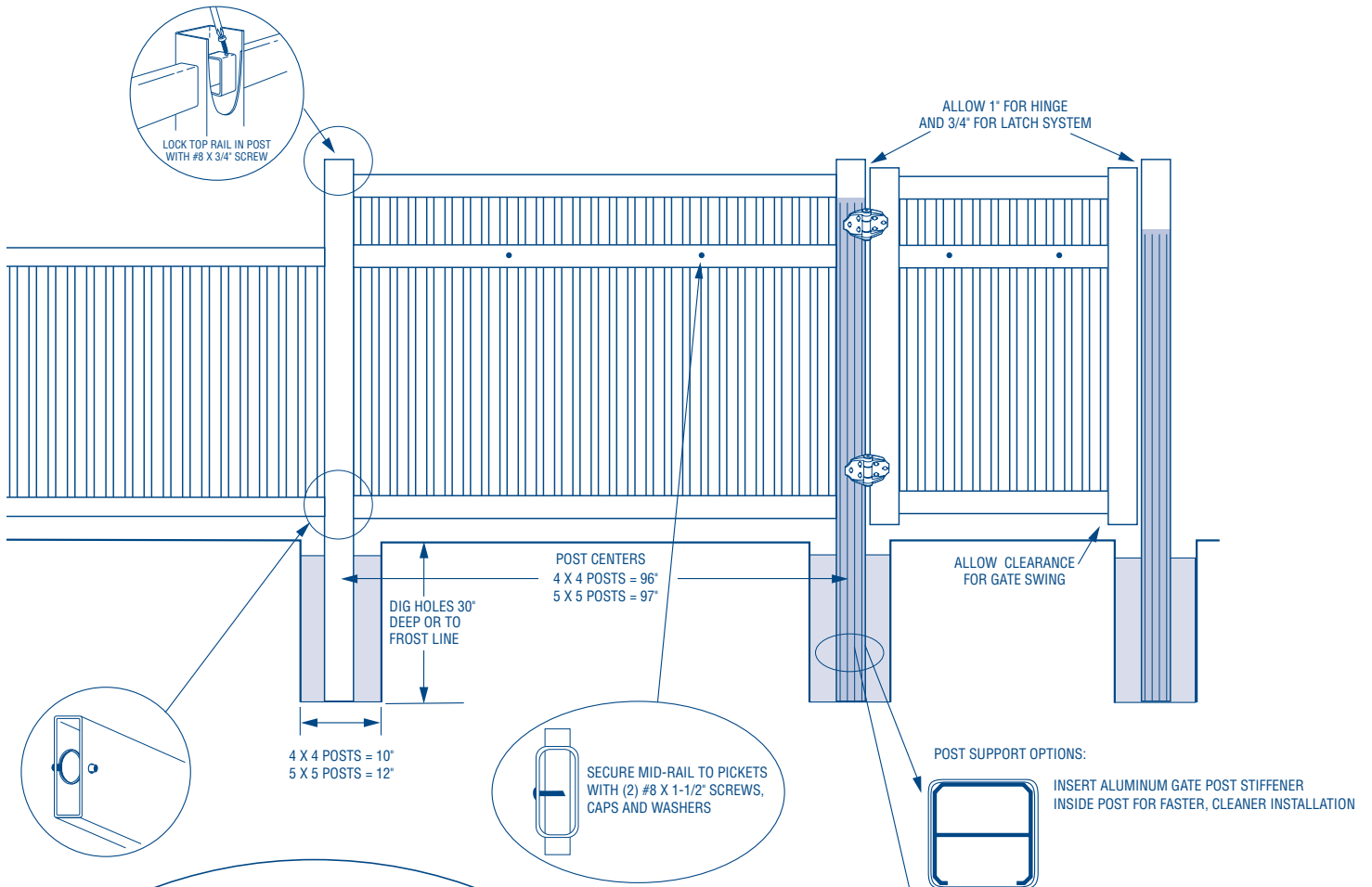

EMBEDMENT DETAIL FOR OPTIONAL LINE POST STIFFENER ALUMINUM INSERT

TO COMPLY WITH THE HIGH VELOCITY HURRICANE ZONES SECTION R44003.1.2.1 OF THE FLORIDA BUILDING CODE, A STEEL INSERT MUST BE ADDED TO THE TOP RAIL AND THE CENTER PICKET MUST BE ATTACHED TO THE TOP AND BOTTOM RAIL WITH (2) #8 X 1-1/2" SCREWS, CAPS, AND WASHERS

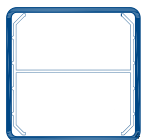

SECTION A-A
LINE POST STIFFENER
ALUMINUM INSERT

MAXIMUM POST SPACING AND FOOTING DIMENSIONS

Wind Exposure	Footing Depth	Max. Post Spacing	
B	30"	97"	NON HVHZ
B	24"	66"	
C	36"	88"	HVHZ and NON HVHZ
C	30"	68"	
D	36"	75"	HVHZ and NON HVHZ
D	30"	56"	

HVHZ: Miami-Dade and Broward counties wind exposures as defined in the ASCE 7-10

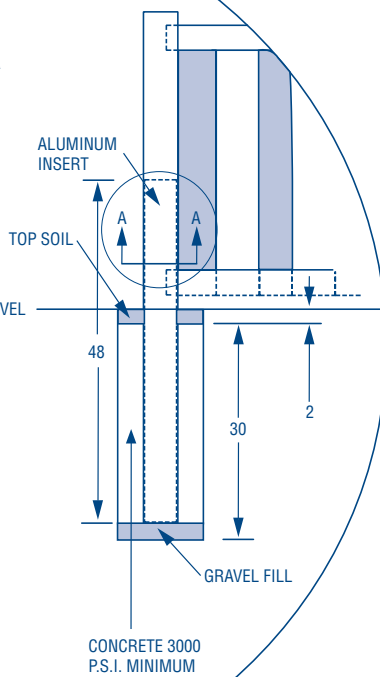

POST SUPPORT OPTIONS:

- INSERT ALUMINUM GATE POST STIFFENER INSIDE POST FOR FASTER, CLEANER INSTALLATION
- USE (2) PIECES OF 1/2" REBAR IN HINGE, LATCH AND END POSTS. POSITION REBAR IN OPPOSING CORNERS OF EACH POST WITH REBAR SEPARATOR CLIPS



FEATURING
WINDZONE™
PERFORMANCE

Semi-Private Fence – Millbrook

1. Getting Started

- Be sure to call underground prior to digging
- Assemble gates (if necessary) and decide where they will be located
- Stake out the fence line
- Space and mark post hole locations for gate and sections (spacer bar/template may be useful)
- Start at gate end post and work outward to determine proper fence height relative to ground

2. Dig Holes

- Dig holes 30" deep or to frost line
 - Hole size for 5 x 5 posts = approximately 12"
- Clean holes and check for straight walls

3. Install First Post

- Insert post in hole
- Determine rough height
- Fill hole around post with concrete mix (sand, gravel and cement) approximately 2" or 4" below grade
- Tamp concrete in hole to eliminate air pockets
- Level and square post

4. Install Bottom Rail

- Tape the ends of any rail being inserted into a post that is to be filled with concrete to prevent concrete seepage
- Insert lock ring in each end of rail
- Depress lock ring tabs and insert rail in post
- Tabs will recoil to hold rail in post

5. Install Second Post

- Insert second post in hole
- Insert bottom rail in post
- Insert block under bottom rail to position at correct fence height
- Fill hole around second post with concrete mix
- Tamp, level and square fence
- Fence assembly may be continued by installing all bottom rails first, or one section at a time

6. Support and Secure

- Level and square fence
- To lower a post, place a wood block from corner to corner on the post and carefully tap with a mallet
- Never strike the PVC post without a wood support

7. Install Pickets and Rails

- Insert mid-rail in post with large holes facing down
- Insert pickets through holes in mid-rail
- Insert pickets in bottom rail. Temporarily remove middle rail ends from post. Insert top rail over pickets
- Insert mid-rail and top rail in post

8. Secure Rails

- Square pickets and rails
- Check for even picket spacing on each end of rail
- Secure rail inside post with a #8 x 3/4" screw (do this on both ends)
- Level mid-rail, secure rail to pickets with (2) #8 x 1-1/2" screws, snap caps and washers evenly spaced along rail

9. Hang Gate/Install Hardware

- For complete details, see gate installation instructions in hardware box
- Position gate between posts
- Allow 1" gap for hinge and 3/4" for latch and gate swing
- Block up gate to square with fence; rails should be level
- Gate hardware must be mounted to two sides of the post

10. Solidify Gate Posts

- It is critical that gate hinge and latch posts are solid to ensure proper gate functionality. Two methods are available:
 - A. Aluminum gate post stiffener
 - Slide aluminum gate stiffener inside hinge, latch or end posts
 - Drive a screw through the vinyl into the aluminum stiffener at the bottom of the post
 - Insert post into the ground
 - Fill hole with concrete around outside of post
 - B. Concrete and rebar*
 - Use two pieces of 1/2" rebar in each hinge, latch and end post
 - Rebar should extend from the bottom of the hole to approximately 12" from the top of the post
 - Hold rebar in opposite corners of post with rebar separator clips
 - Fill post with concrete mix to cover rebar and hardware fasteners
 - Tamp post with a rubber mallet to eliminate air pockets
 - Leave gate on blocks for 72 hours to allow concrete to set

11. Install Caps

- Install post caps
- Caps may be secured with glue, silicone adhesive or #8 x 3/4" screws, caps and washers

Semi-Private Fence

Includes: Millbrook

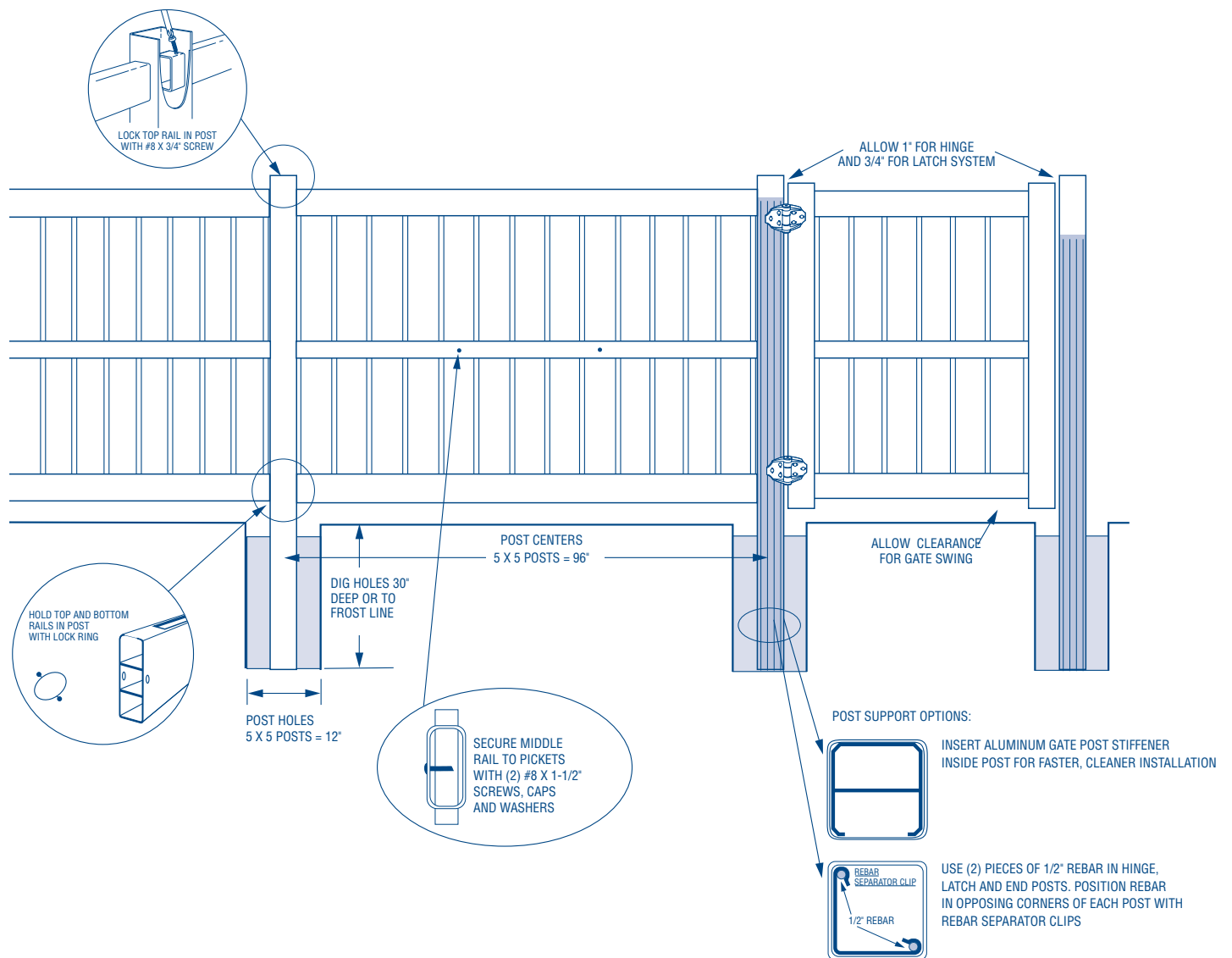

Privacy Fence – Chesterfield, Chesterfield with CertaGrain® Texture, Chesterfield with CertaStucco™ Texture

1. Getting Started

- Be sure to call underground prior to digging
- Assemble gates (if necessary) and decide where they will be located
- Stake out the fence line
- Space and mark post hole locations for gate and sections (spacer bar/template may be useful)
- Start at gate end post and work outward to determine proper fence height relative to ground

2. Dig Holes

- Dig holes 30" deep or to frost line
 - Hole size for 5 x 5 posts = approximately 12"
- Clean holes and check for straight walls

3. Install First Post

- Insert post in hole
- Determine rough height
- Fill hole around post with concrete mix (sand, gravel and cement) approximately 2" or 4" below grade
- Tamp concrete in hole to eliminate air pockets
- Level and square post

4. Install Bottom Rail

- Tape the ends of any rail going into a post that is to be filled with concrete to prevent concrete seepage
- Insert lock ring in both ends of bottom rail
- Depress lock ring tabs, insert bottom rail in post
- Tabs will recoil to hold rail in post

5. Install Second Post

- Insert second post in hole
- Insert bottom rail in post
- Insert block under bottom rail to position of correct fence height
- Fill hole around second post with concrete mix
- Tamp, level and square fence
- Assembly may be continued by installing all bottom rails first or one section at a time

6. Support and Secure

- Level and square fence
- To lower a post, place a wood block from corner to corner of the post and carefully tap with a mallet
- Never strike the PVC post without a wood support

7. Picket End Channel

- When installing Arbor Blend, Arctic Blend, Brazilian Blend, Canyon Blend, Frontier Blend, Honey Blend, Natural Clay, Sierra Blend, Timber Blend or Weathered Blend, picket end channels are required (2 per section)
- Cut end channel to length
- Center channel on post between routed holes
- Attach channel to post in four locations

8. Install Pickets and Rails

- Pickets are cut at a 5° angle to accommodate a 1' slope
- Insert pickets in bottom rail
- Insert top rail over pickets
- Depress lock ring tabs, insert top rail in post

9. Hang Gate/Install Hardware

- For complete details, see gate installation instructions in hardware box
- Position gate between posts
- Allow 1" gap for hinge and 3/4" for latch and gate swing
- Block up gate to square with fence; rails should be level
- Gate hardware must be mounted to two sides of the post

10. Solidify Gate Posts

- It is critical that gate hinge and latch posts are solid to ensure proper gate functionality. Two methods are available:
 - A. Aluminum gate post stiffener
 - Slide aluminum gate stiffener inside hinge, latch or end posts
 - Drive a screw through the vinyl into the aluminum stiffener at the bottom of the post
 - Insert post into the ground
 - Fill hole with concrete around outside of post
 - B. Concrete and rebar*
 - Use two pieces of 1/2" rebar in each hinge, latch and end post
 - Rebar should extend from the bottom of the hole to approximately 12" from the top of the post
 - Hold rebar in opposite corners of post with rebar separator clips
 - Fill post with concrete mix to cover rebar and hardware fasteners
 - Tamp post with a rubber mallet to eliminate air pockets
 - Leave gate on blocks for 72 hours to allow concrete to set

11. Install Caps

- Install post caps
- Caps may be secured with glue, silicone adhesive or #8 x 3/4" screws, caps and washers

For accents, see pages 27 and 28

Privacy Fence

Includes: Chesterfield
 Chesterfield with CertaGrain® Texture
 Chesterfield with CertaStucco™ Texture

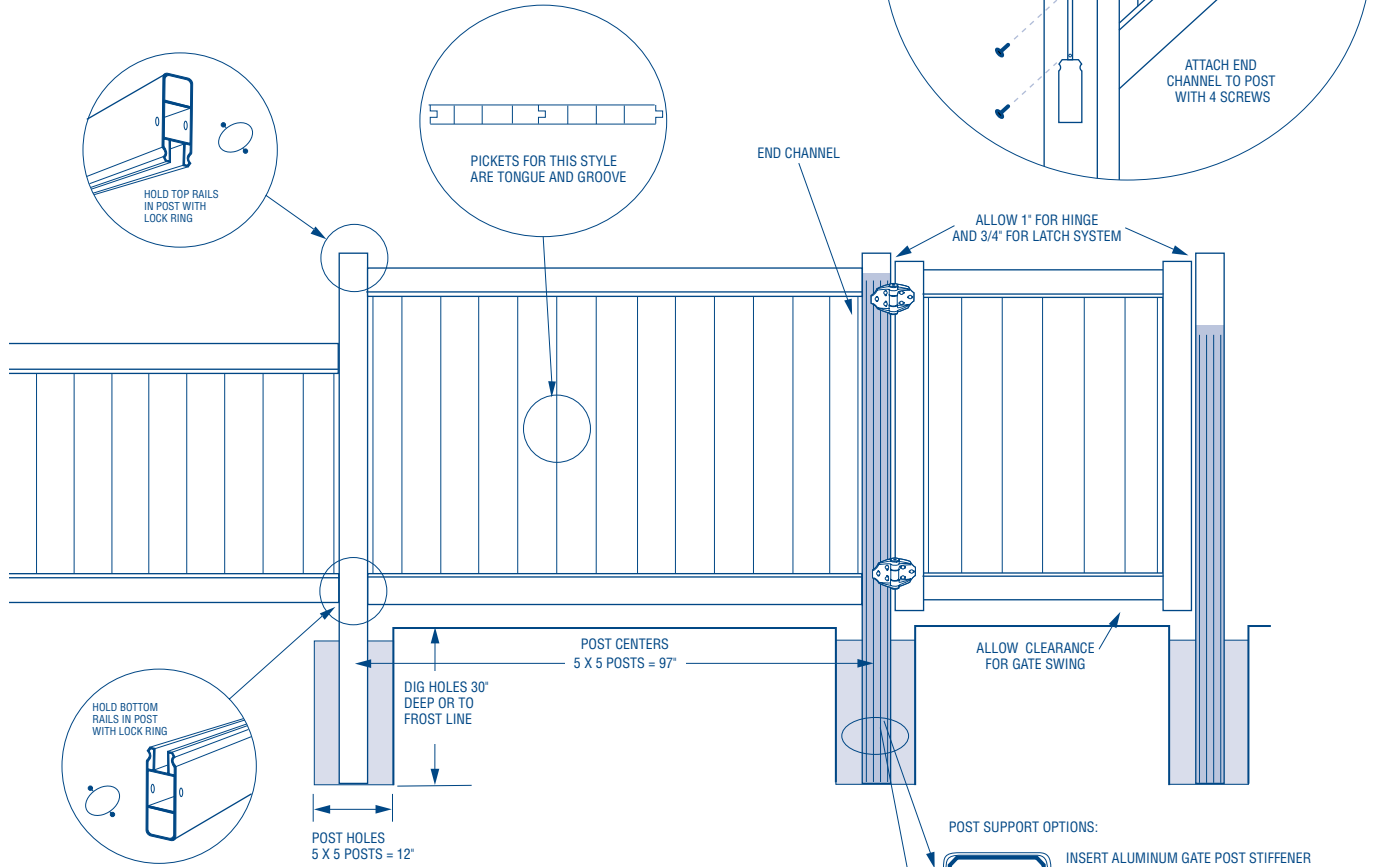

EMBEDMENT DETAIL FOR OPTIONAL LINE POST STIFFENER ALUMINUM INSERT

MINIMUM 48" INSERT REQUIRED TO COMPLY WITH THE HIGH VELOCITY HURRICANE ZONES SECTION R44003.1.2.1 OF THE FLORIDA BUILDING CODE

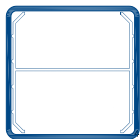

SECTION A-A
 LINE POST STIFFENER
 ALUMINUM INSERT

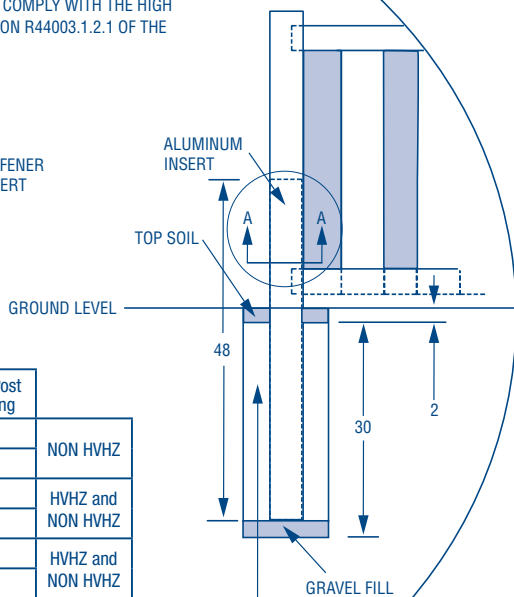

MAXIMUM POST SPACING AND FOOTING DIMENSIONS

Wind Exposure	Footing Depth	Max. Post Spacing	
B	30"	97"	NON HVHZ
B	24"	66"	
C	36"	88"	HVHZ and NON HVHZ
C	30"	68"	
D	36"	75"	HVHZ and NON HVHZ
D	30"	56"	

HVHZ: Miami-Dade and Broward counties wind exposures as defined in the ASCE 7-10

CONCRETE 3000 P.S.I. MINIMUM

POST SUPPORT OPTIONS:



INSERT ALUMINUM GATE POST STIFFENER INSIDE POST FOR FASTER, CLEANER INSTALLATION

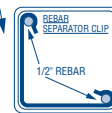

USE (2) PIECES OF 1/2" REBAR IN HINGE, LATCH AND END POSTS. POSITION REBAR IN OPPOSING CORNERS OF EACH POST WITH REBAR SEPARATOR CLIPS



FEATURING
WINDZONE™
 PERFORMANCE

Privacy Fence – Chesterfield with Huntington Accent, Chesterfield with Westminster Accent

1. Getting Started

- Be sure to call underground prior to digging
- Assemble gates (if necessary) and decide where they will be located
- Stake out the fence line
- Space and mark post hole locations for gate and sections (spacer bar/template may be useful)
- Start at gate end post and work outward to determine proper fence height relative to ground

2. Dig Holes

- Dig holes 30" deep or to frost line
 - Hole size for 5 x 5 posts = approximately 12"
- Clean holes and check for straight walls

3. Install First Post

- Insert post in hole
- Determine rough height
- Fill hole around post with concrete mix (sand, gravel and cement) approximately 2" or 4" below grade
- Tamp concrete in hole to eliminate air pockets
- Level and square post

4. Install Bottom Rail

- Tape the ends of any rail being inserted into a post that is to be filled with concrete to prevent concrete seepage
- Insert lock ring in each end of rail
- Depress lock ring tabs and insert rail in post. Tabs will recoil to hold rail in post

5. Install Second Post

- Insert second post in hole
- Insert bottom rail in post
- Insert block under bottom rail to position at correct fence height
- Fill hole around second post with concrete mix
- Tamp, level and square fence
- Assembly may be continued by installing all bottom rails first, or one section at a time

6. Support and Secure

- Level and square fence
- To lower a post, place a wood block from corner to corner on the post and carefully tap with a mallet
- Never strike the PVC post without a wood support

7. Picket End Channel

- Cut end channel to length
- Center channel on post between routed holes
- Attach channel to post in four locations

8. Install Pickets and Rails

- Insert pickets in bottom rail
- Insert top rail over pickets
- Depress lock rings tabs, insert top rail in post

9. Install Accents

• Huntington

- Insert top 2 x 3-1/2 rail with larger holes facing down into post
- Insert pickets through rail and lock into top fence section rail (pickets are factory crimped to hold in place)
- To create desired scalloped effect, longer length pickets will need to be cut and then crimped, or a bullet clip may be inserted to hold picket in rail

• Westminster

- Insert bottom and side channels (overlap ends) into position on rail and posts - secure with #8 x 1-1/2" screws
- Insert lattice into channels
- Slide top channel over lattice
- Insert top 2 x 3-1/2 rail into routed post holes
- Secure top channel 2 x 3-1/2 top rail with #8 x 1-1/2" screws

10. Hang Gate/Install Hardware

- For complete details, see gate installation instructions in hardware box
- Position gate between posts
- Allow 1" gap for hinge and 3/4" for latch and gate swing
- Block up gate to square with fence; rails should be level
- Gate hardware must be mounted to two sides of the post

11. Solidify Gate Posts

- It is critical that gate hinge and latch posts are solid to ensure proper gate functionality. Two methods are available:
 - A. Aluminum gate post stiffener
 - Slide aluminum gate stiffener inside hinge, latch or end posts
 - Drive a screw through the vinyl into the aluminum stiffener at the bottom of the post
 - Insert post into the ground
 - Fill hole with concrete around outside of post
 - B. Concrete and rebar*
 - Use two pieces of 1/2" rebar in each hinge, latch and end post
 - Rebar should extend from the bottom of the hole to approximately 12" from the top of the post
 - Hold rebar in opposite corners of post with rebar separator clips
 - Fill post with concrete mix to cover rebar and hardware fasteners
 - Tamp post with a rubber mallet to eliminate air pockets
 - Leave gate on blocks for 72 hours to allow concrete to set

12. Install Caps

- Install post caps
- Caps may be secured with glue, silicone adhesive or #8 x 1-1/2" screws, caps and washers

* Caution – In climates that experience freeze-thaw cycles, this installation method could result in post cracking over time. This would not be covered by the warranty.

Privacy Fence

Includes: Chesterfield with Huntington Accent
 Chesterfield with Westminster Accent

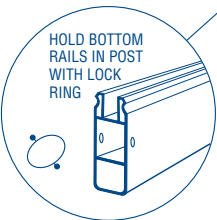
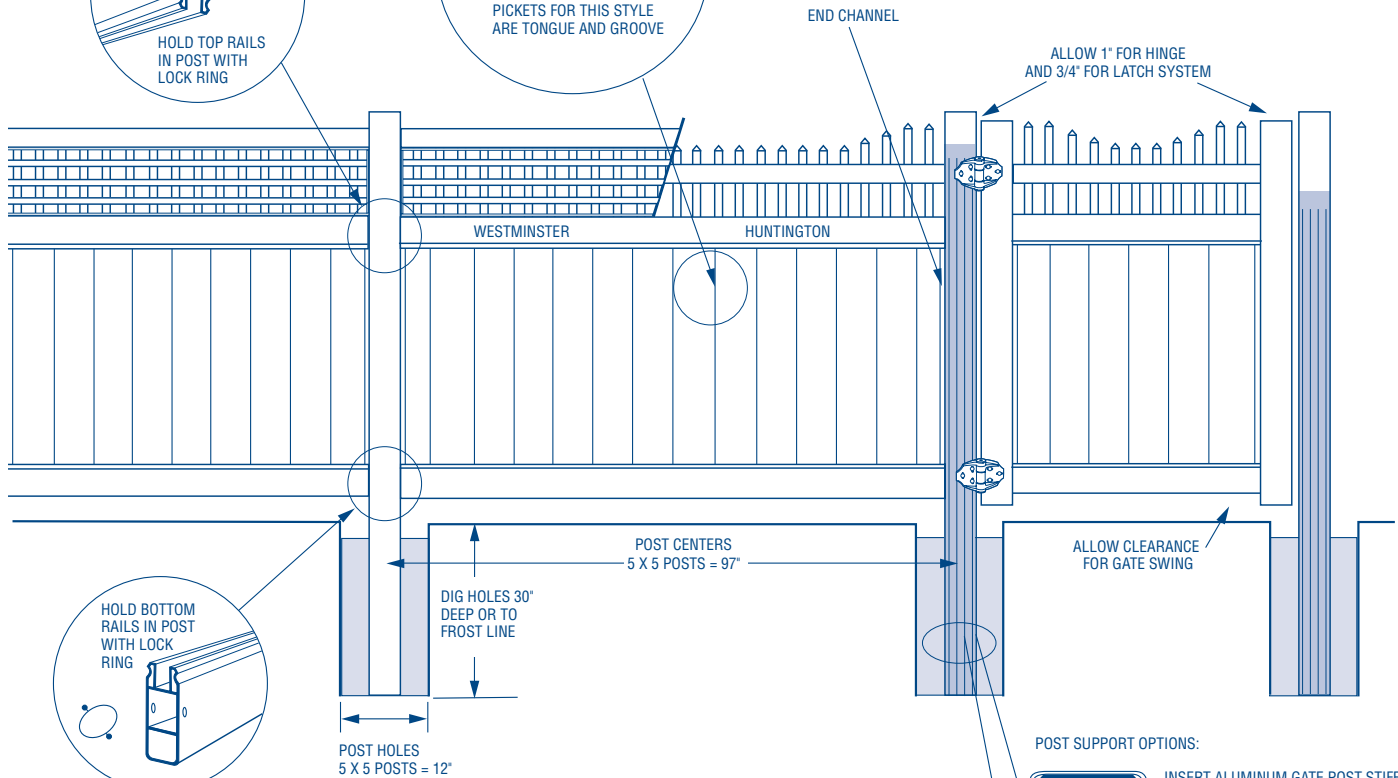
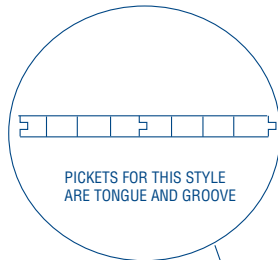
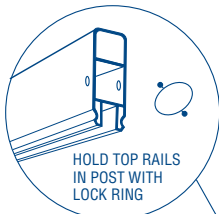
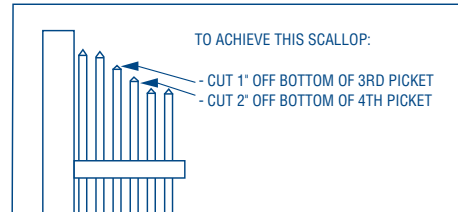
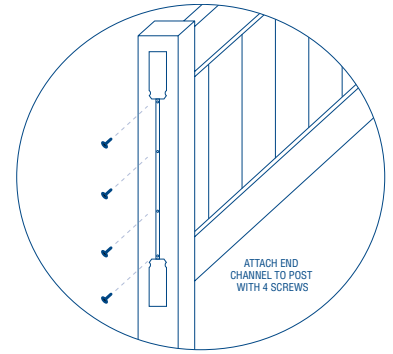

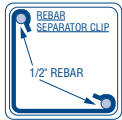
- POST SUPPORT OPTIONS:
- 
 INSERT ALUMINUM GATE POST STIFFENER INSIDE POST FOR FASTER, CLEANER INSTALL
 - 
 USE (2) PIECES OF 1/2" REBAR IN HINGE, LATCH AND END POSTS. POSITION REBAR IN OPPOSING CORNERS OF EACH POST WITH REBAR SEPARATOR CLIPS

Privacy Fence – Galveston, Galveston with CertaGrain® Texture

1. Getting Started

- Be sure to call underground prior to digging
- Assemble gates (if necessary) and decide where they will be located
- Stake out the fence line
- Space and mark post hole locations for gate and sections (spacer bar/template may be useful)
- Start at gate end post and work outward to determine proper fence height relative to ground

2. Dig Holes

- Dig holes 30" deep or to frost line
 - Hole size for 5 x 5 posts = approximately 12"
- Clean holes and check for straight walls

3. Install First Post

- Insert post in hole
- Determine rough height
- Fill hole around post with concrete mix (sand, gravel and cement) approximately 2" or 4" below grade
- Tamp concrete in hole to eliminate air pockets
- Level and square post

4. Install Bottom Rail

- Tape the ends of any rail going into a post that is to be filled with concrete to prevent concrete seepage
- Insert lock ring in both ends of bottom rail
- Depress lock ring tabs, insert bottom rail in post
- Tabs will recoil to hold rail in post

5. Install Second Post

- Insert second post in hole
- Insert bottom rail in post
- Insert block under bottom rail to position at correct fence height
- Fill hole around second post with concrete mix
- Tamp, level and square fence
- Assembly may be continued by installing all bottom rails first or one section at a time

6. Support and Secure

- Level and square fence
- To lower a post, place a wood block from corner to corner of the post and carefully tap with a mallet
- Never strike the PVC post without a wood support

7. Picket End Channel

- When installing Arbor Blend, Arctic Blend, Brazilian Blend, Frontier Blend, Honey Blend, Natural Clay, Sierra Blend or Weathered Blend, picket end channels are required (4 per section)
- Cut end channel to length
- Center channel on post between routed holes
- Attach channel to post in four locations

8. Install Pickets and Rails

- Insert pickets in bottom rail
- Insert mid-rail over pickets
- Depress lock ring tabs, insert mid-rail in post
- Insert next row of pickets in mid-rail
- Insert top rails over pickets
- Depress lock ring tabs, insert top rail in post

9. Hang Gate/Install Hardware

- Position gate between posts
- Allow 1" gap for hinge and 3/4" for latch and gate swing
- Block up gate to square with fence; rails should be level
- Gate hardware must be mounted to two sides of the post
- For complete details, see gate installation instructions in hardware box
- Galveston gate requires 3 hinges

10. Solidify Gate Posts

- It is critical that gate hinge and latch posts are solid to ensure proper gate functionality. Two methods are available:
 - A. Aluminum gate post stiffener
 - Slide aluminum gate stiffener inside hinge, latch or end posts
 - Drive a screw through the vinyl into the aluminum stiffener at the bottom of the post
 - Insert post into the ground
 - Fill hole with concrete around outside of post
 - B. Concrete and rebar*
 - Use two pieces of 1/2" rebar in each hinge, latch and end post
 - Rebar should extend from the bottom of the hole to approximately 12" from the top of the post
 - Hold rebar in opposite corners of post with rebar separator clips
 - Fill post with concrete mix to cover rebar and hardware fasteners
 - Tamp post with a rubber mallet to eliminate air pockets
 - Leave gate on blocks for 72 hours to allow concrete to set

11. Reinforce Posts

Concrete and Rebar

- Insert two pieces of rebar in all end, line and corner posts. Fill with concrete mix to cover rebar at a height 1" below mid-rail
- Tamp post with a rubber mallet to eliminate air pockets

Aluminum Line Post Insert

- Length of aluminum insert should extend from bottom of posts to 4" below mid-rail

12. Install Caps

- Install post caps
- Caps may be secured with glue, silicone adhesive or #8 x 3/4" screws, caps and washers

For accents, see pages 27 and 28

Privacy Fence

Includes: Galveston
Galveston with CertaGrain® Texture

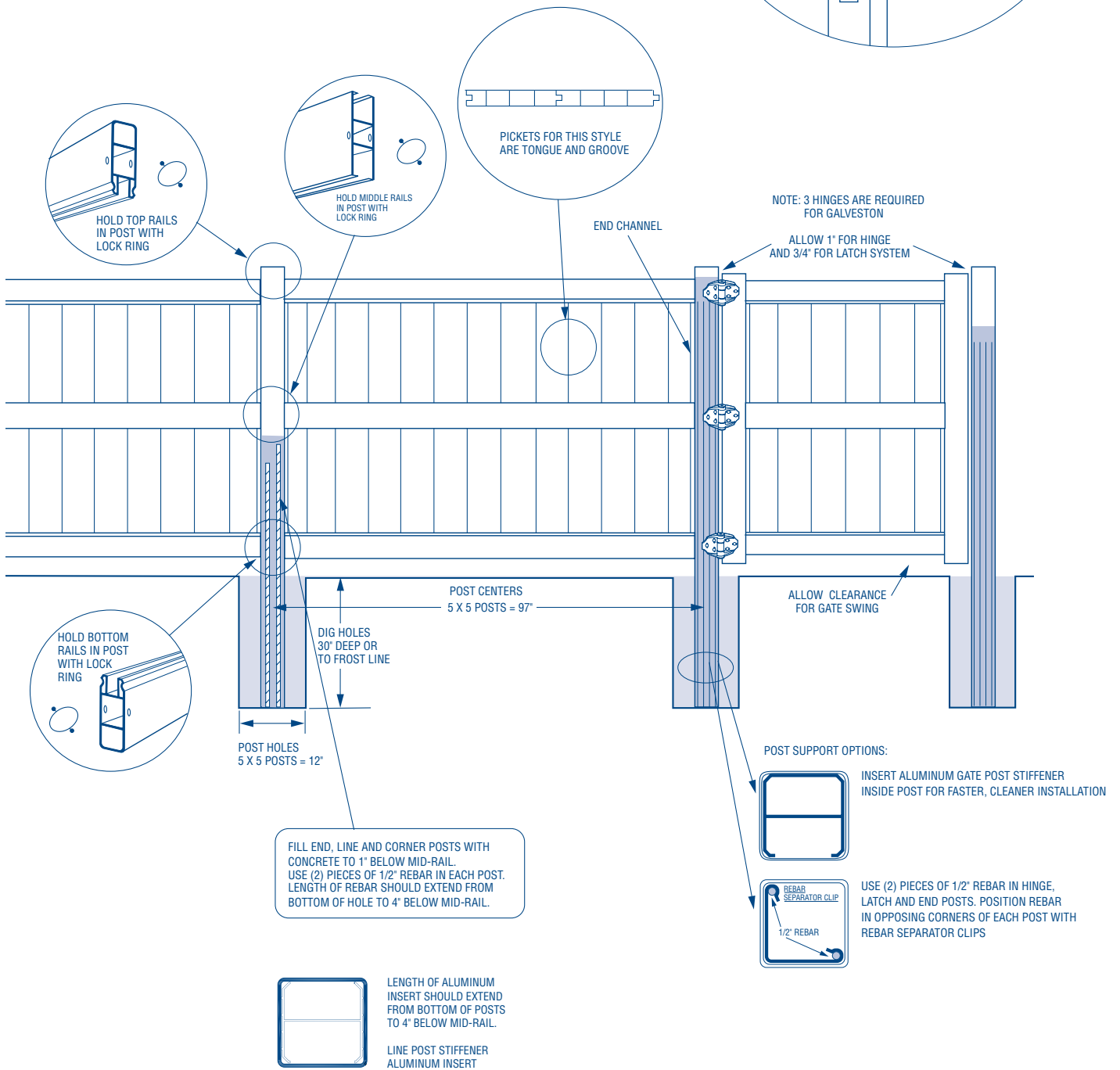
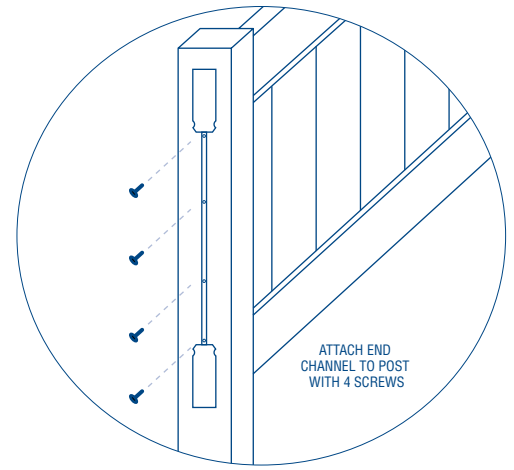

Privacy Fence – New Lexington

1. Getting Started

- Be sure to call underground prior to digging
- Assemble gates (if necessary) and decide where they will be located
- Stake out the fence line
- Space and mark post hole locations for gate and sections (spacer bar/template may be useful)
- Start at gate end post and work outward to determine proper fence height relative to ground

2. Dig Holes

- Dig holes 30" deep or to frost line
 - Hole size for 5 x 5 posts = approximately 12"
- Clean holes and check for straight walls

3. Install First Post

- Insert post in hole
- Determine rough height
- Fill hole around post with concrete mix (sand, gravel and cement) approximately 2" or 4" below grade
- Tamp concrete in hole to eliminate air pockets
- Level and square post

4. Install Bottom Rail

- Tape the ends of any rail going into a post that is to be filled with concrete to prevent concrete seepage
- Insert lock ring in both ends of bottom rail
- Depress lock ring tabs, insert bottom rail in post
- Tabs will recoil to hold rail in post

5. Install Second Post

- Insert second post in hole
- Insert bottom rail in post
- Insert block under bottom rail to position of correct fence height
- Fill hole around second post with concrete mix
- Tamp, level and square fence
- Assembly may be continued by installing all bottom rails first or one section at a time

6. Support and Secure

- Level and square fence
- To lower a post, place a wood block from corner to corner of the post and carefully tap with a mallet
- Never strike the PVC post without a wood support

7. Picket End Channel

- Cut end channel to length
- Center channel on post between routed holes
- Attach channel to post in four locations

8. Install Pickets and Rails

- Pickets are cut at a 3° angle for racking
- Insert pickets in bottom rail
- Insert top rail over pickets
- Depress lock ring tabs, insert top rail in post

9. Hang Gate/Install Hardware

- For complete details, see gate installation instructions in hardware box
- Position gate between posts
- Allow 1" gap for hinge and 3/4" for latch and gate swing
- Block up gate to square with fence; rails should be level
- Gate hardware must be mounted to two sides of the post

10. Solidify Gate Posts

- It is critical that gate hinge and latch posts are solid to ensure proper gate functionality. Two methods are available:
 - A. Aluminum gate post stiffener
 - Slide aluminum gate stiffener inside hinge, latch or end posts
 - Drive a screw through the vinyl into the aluminum stiffener at the bottom of the post
 - Insert post into the ground
 - Fill hole with concrete around outside of post
 - B. Concrete and rebar*
 - Use two pieces of 1/2" rebar in each hinge, latch and end post
 - Rebar should extend from the bottom of the hole to approximately 12" from the top of the post
 - Hold rebar in opposite corners of post with rebar separator clips
 - Fill post with concrete mix to cover rebar and hardware fasteners
 - Tamp post with a rubber mallet to eliminate air pockets
 - Leave gate on blocks for 72 hours to allow concrete to set

11. Install Caps

- Install post caps
- Caps may be secured with glue, silicone adhesive or #8 x 3/4" screws, caps and washers

For accents, see pages 27 and 28

Privacy Fence

Includes: New Lexington

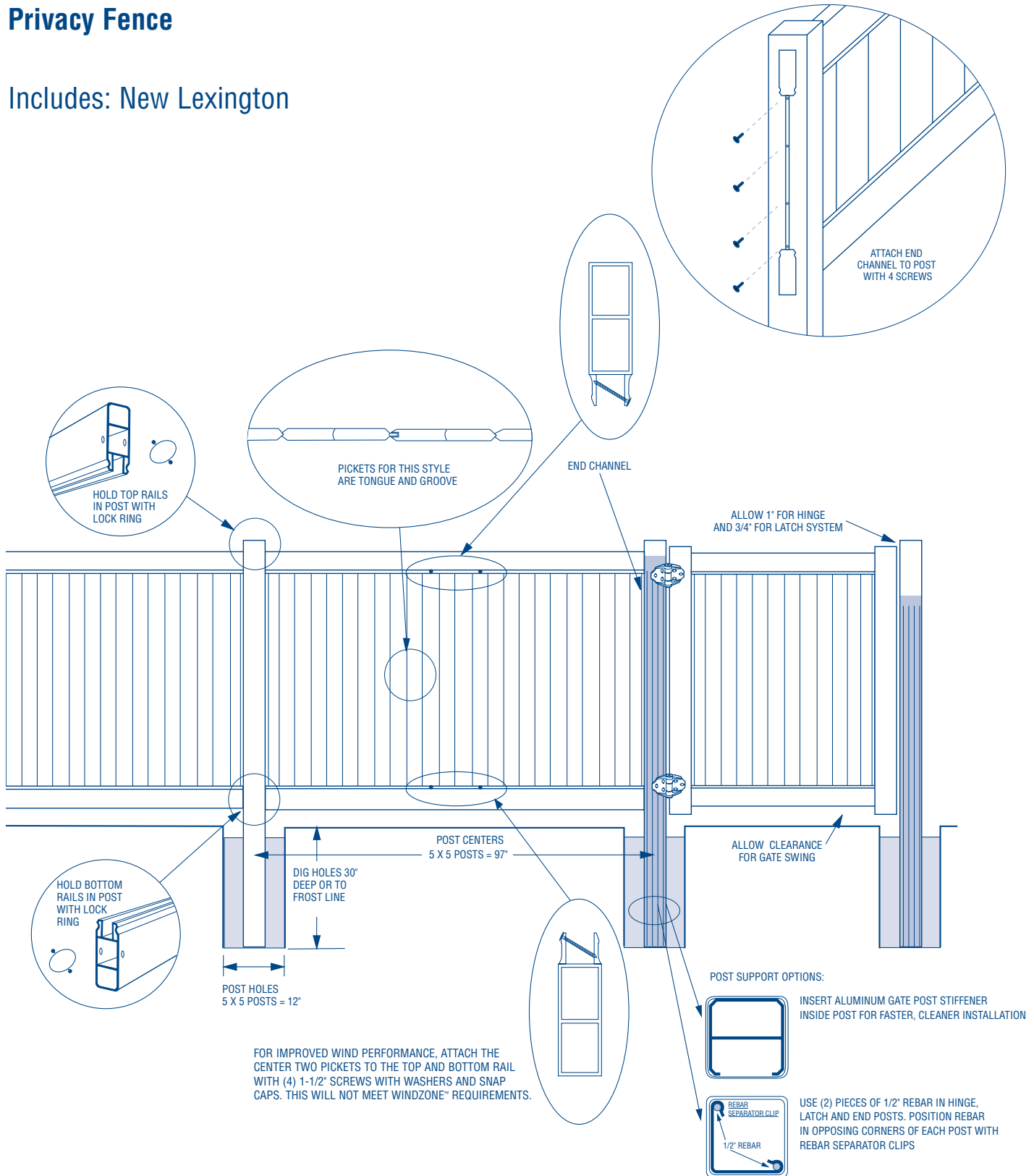

Accent Fence

Includes: Lattice, Victorian

Once the main fence section is installed, proceed as follows:

Lattice

- Measure distance between inside faces of the posts
- Cut bottom channel to fit between posts
- Fasten bottom channel to top fence rail with #8 X 1-1/2" screws evenly spaced along the length
- Fasten side channels to posts with #8 X 1-1/2" screws
- Insert lattice into channels
- Slide top channel over lattice
- Insert top 2 X 3-1/2 rail into routed post holes
- Secure top channel to 2 X 3-1/2 top rail with #8 X 1-1/2" screws evenly spaced along the length

Victorian

- Insert accent pickets in routed section top rail
- Insert top accent rail over pickets
- Insert both ends of top rail into routed post holes
- Secure top rail in position with #8 x 3/4" screws from inside the post

SHOWN WITH CHESTERFIELD FENCE

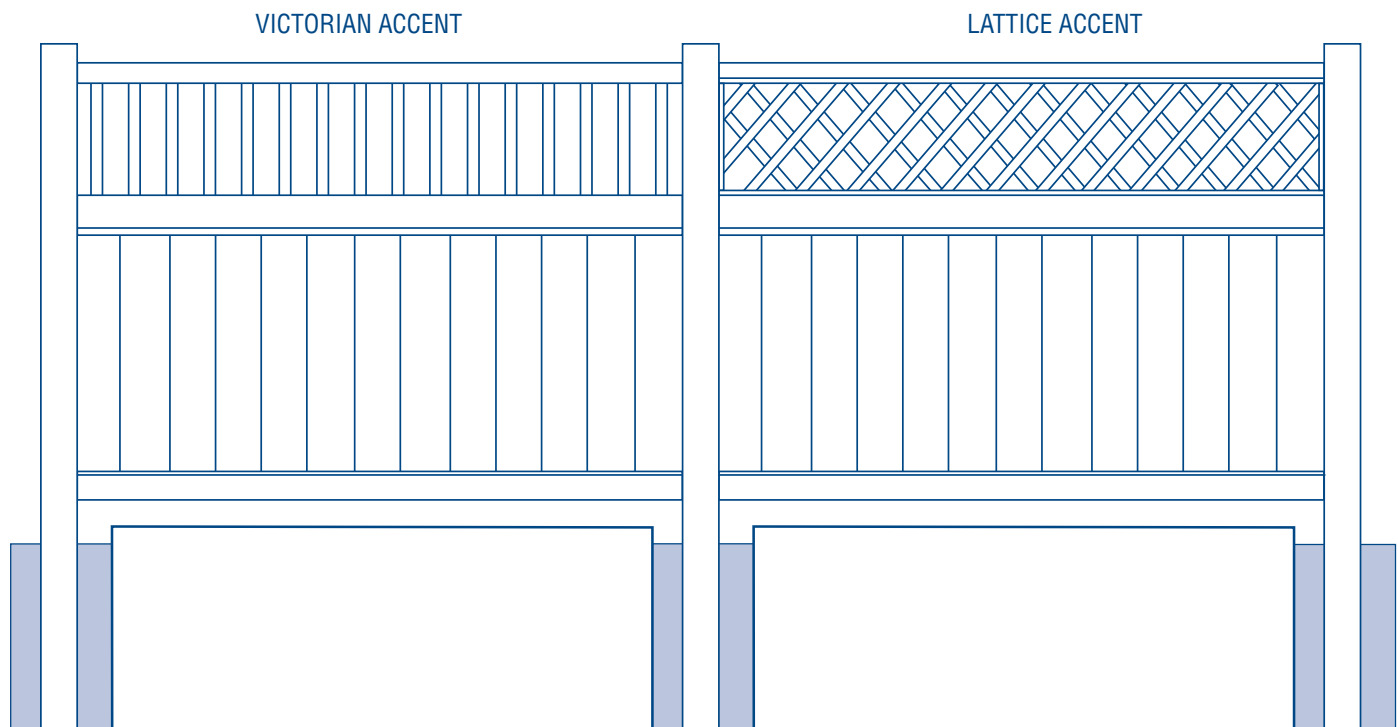

Accent Fence

Includes: Lattice – New Lexington, Chesterfield with CertaGrain® Texture

Once the main fence section is installed, proceed as follows:

Lattice

- Leave one end of top rail out of post
- Starting at the end, slide lattice into top rail channel
- Insert rail into routed post, secure with lock ring
- Starting at the end, slide top channel over lattice
- Insert both ends of top channel into routed post
- Secure rail inside post with #8 x 3/4" screw (do this on both ends)

SHOWN WITH NEW LEXINGTON FENCE
LATTICE ACCENT

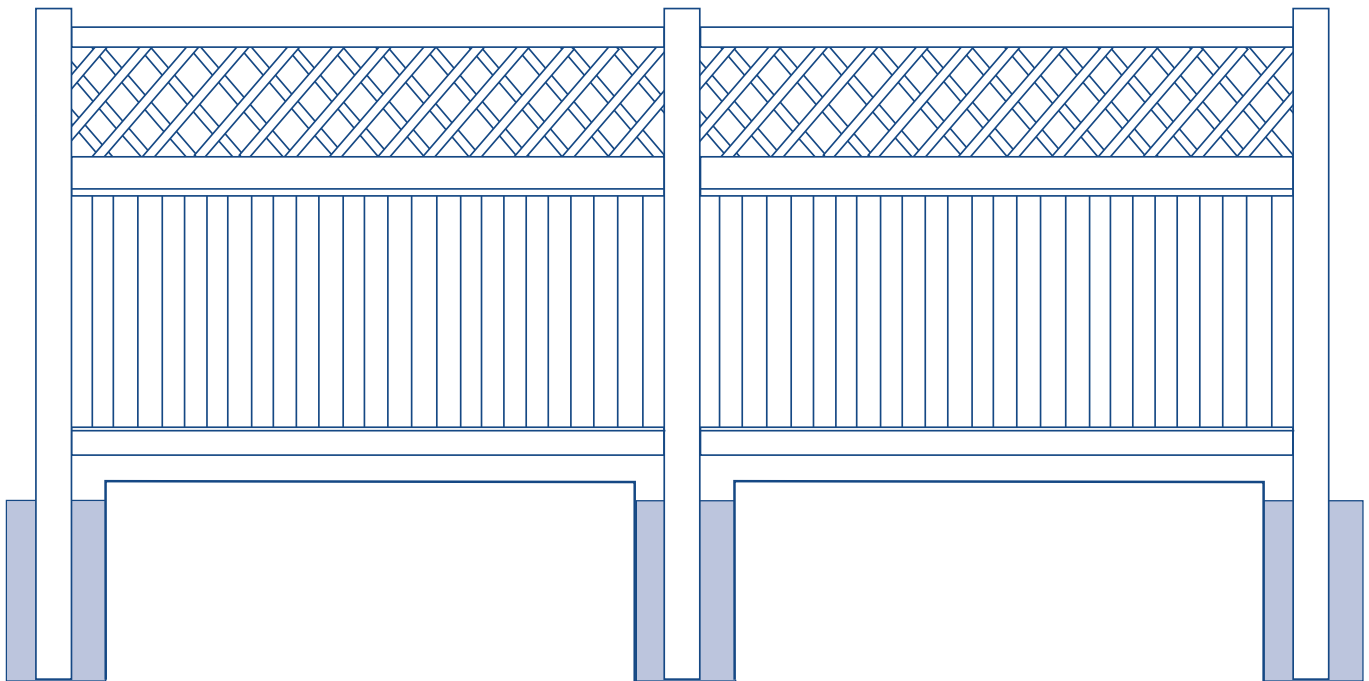

Curved Rail

Includes: Concave, Convex, "S" Curve and Swoop



1. Set Posts



2. Insert Pickets in Bottom Rail



3. Insert Top Rail into Post Holes



4. Trace the Outline of the Rail onto the Pickets

Mark each picket with an X on the scrap side of line

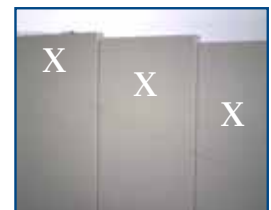

Curved Rail

Includes: Concave, Convex, "S" Curve and Swoop



5. Cut Pickets

- Remember to wear safety glasses when cutting
- Use pencil line as guide only — DO NOT CUT ALONG PENCIL LINE
- Blade should cut approximately 1-1/4 above the line to allow picket to enter rail
- To practice safety, remove pickets and cut on a flat, secure surface

6. Picket End Channel

- Cut end channel to length
- Center channel on post between routed holes
- Attach channel to post in four locations

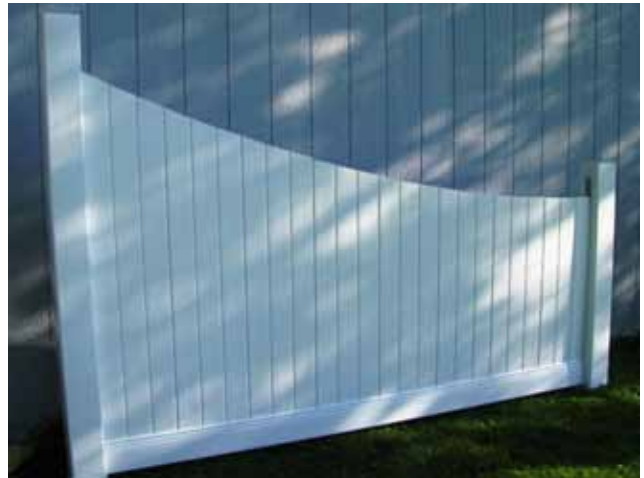

7. Insert Pickets into Bottom Rail



8. Slide Top Rail over Pickets

9. Insert Locking Rings

10. Insert Rail into Post Holes

Post & Rail – Crossbuck, 2-Rail, 3-Rail and 4-Rail

1. Getting Started

- Be sure to call underground prior to digging
- Assemble gates (if necessary) and decide where they will be located
- Stake out the fence line
- Space and mark post hole locations for gate and sections (spacer bar/template may be useful)
- Start at gate end post and work outward to determine proper fence height relative to ground

2. Dig Holes

- Dig holes 30" deep or to frost line
 - Hole size for 5 x 5 posts = approximately 12"
- Clean holes and check for straight walls

3. Install First Post

- Insert post in hole
- Determine rough height
- Fill hole around post with concrete mix (sand, gravel and cement) approximately 2" or 4" below grade
- Tamp concrete in hole to eliminate air pockets
- Level and square post
- Fence may be installed post and bottom rails first, then upper rails

4. Install Rails

- Tape the ends of any rail going into a post that is to be filled with concrete to prevent concrete seepage
- Standard rails are supplied in 16 foot lengths
- For rolling terrain, rails may need to be cut to 95-1/2"
- The starting point for rails should be staggered from post to post for bottom/mid/top rail for maximum strength
- Insert lock ring into one end of rail by depressing tabs, insert in rail end and release
- Depress lock ring tabs to insert bottom rail in first post
- Tabs will recoil to hold rail in post
- If bottom rail is 16' long, slide rail through second post and then insert post in ground
- Insert lock ring in rail end, insert end into third post
- When installing rails leave a 1" gap between rail ends inside post to allow for expansion

5. Support and Secure

- Block up bottom rail to determine correct fence height
- Fill holes around posts with concrete mix
- Tamp, level and square
- Fence assembly may be continued by installing all bottom rails first or one section at a time
- To lower a post, place a wood block from corner to corner of the post and carefully tap with a mallet
- Never strike the PVC post without a wood support

6. Crossbuck

- Insert lock rings in diagonal rails and insert into each post

Note: Standard diagonal rails are cut to 97" to compensate for angle of install

7. Hang Gate/Install Hardware

- For complete details, see gate installation instructions in hardware box
- Position gate between posts
- Allow 1-1/2" gap on hinge side of the gate and 1-1/4" on latch side to allow for the gate swing and hardware
- Block up gate to square with fence; rails should be level
- Gate hardware must be mounted to two sides of the post

8. Solidify Gate Posts

- It is critical that gate hinge and latch posts are solid to ensure proper gate functionality. Two methods are available:
 - A. Aluminum gate post stiffener
 - Slide aluminum gate stiffener inside hinge, latch or end posts
 - Drive a screw through the vinyl into the aluminum stiffener at the bottom of the post
 - Insert post into the ground
 - Fill hole with concrete around outside of post
 - B. Concrete and rebar*
 - Use two pieces of 1/2" rebar in each hinge, latch and end post
 - Rebar should extend from the bottom of the hole to approximately 12" from the top of the post
 - Hold rebar in opposite corners of post with rebar separator clips
 - Fill post with concrete mix to cover rebar and hardware fasteners
 - Tamp post with a rubber mallet to eliminate air pockets
 - Leave gate on blocks for 72 hours to allow concrete to set

9. Install Caps

- Install post caps by pressing in place inside post

Post & Rail Fence

Includes: Crossbuck, 2-Rail, 3-Rail and 4-Rail

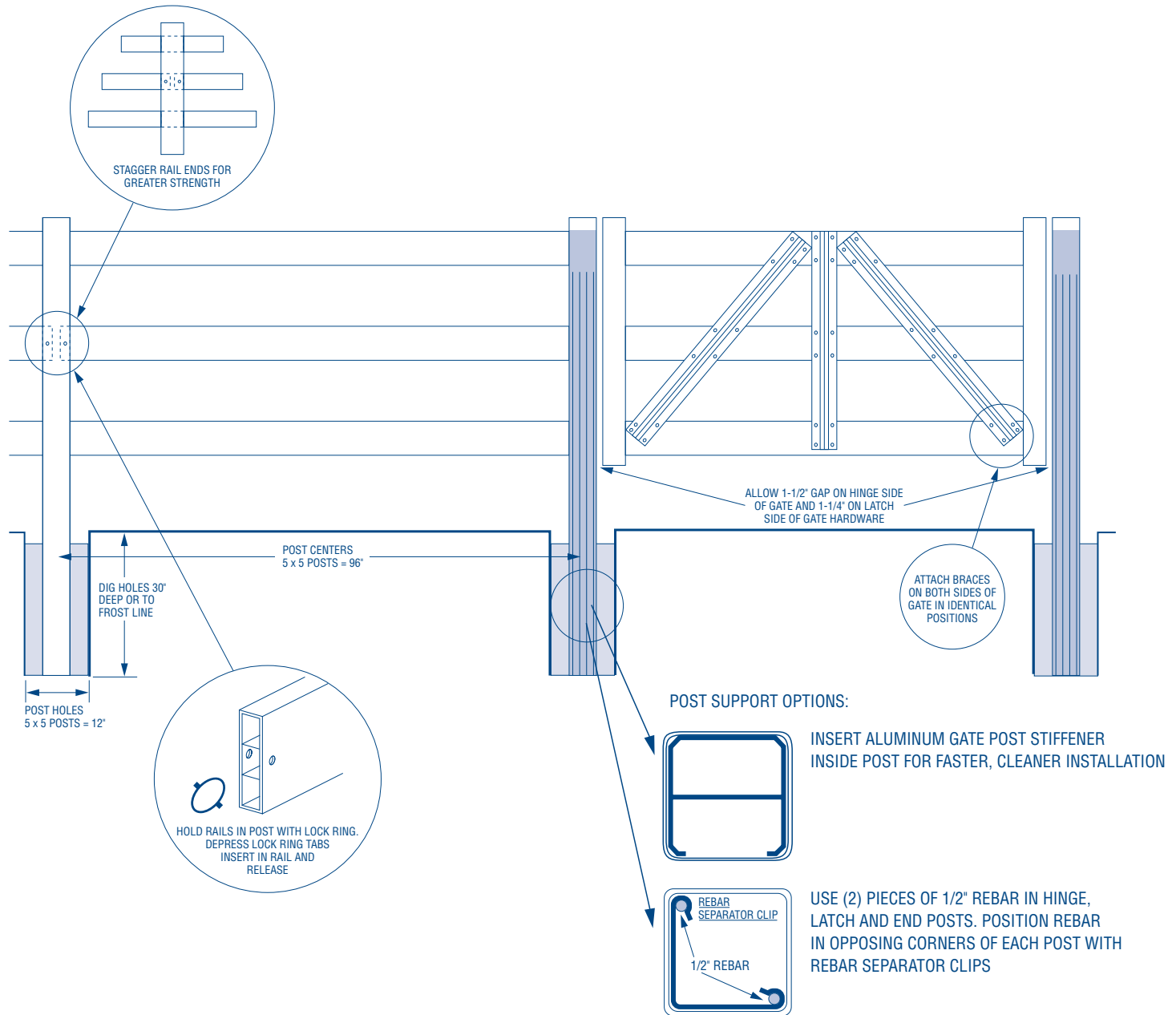

Post & Rail with CertaGrain® Texture – 2-Rail, 3-Rail and 4-Rail

1. Getting Started

- Be sure to call underground prior to digging
 - Assemble gates (if necessary) and decide where they will be located
 - Stake out the fence line
 - Space and mark post hole locations for gate and sections (spacer bar/template may be useful)
 - Start at gate end post and work outward to determine proper fence height relative to ground
- *In climates where the temperature exceeds 100° Fahrenheit, we recommend installing Arctic Blend, Brazilian Blend, Sierra Blend and Weathered Blend products on 6' post centers

2. Dig Holes

- Dig holes 30" deep or to frost line
 - Hole size for 5 x 5 posts = approximately 12"
- Clean holes and check for straight walls

3. Install First Post

- Insert post in hole
- Determine rough height
- Fill hole around post with concrete mix (sand, gravel and cement) approximately 2" or 4" below grade
- Tamp concrete in hole to eliminate air pockets
- Level and square post
- Fence may be installed post and bottom rails first, then upper rails

4. Install Rails

- White product uses 1-1/2 x 5-1/2 rails
- Arctic Blend, Brazilian Blend, Sierra Blend and Weathered Blend use 2 x 6 rails
- Tape the ends of any rail going into a post that is to be filled with concrete to prevent concrete seepage
- Standard rails are supplied in 16 foot lengths for White (12 foot rails for Blend products)
- For rolling terrain, rails may need to be shortened
- The starting point for rails should be staggered from post to post for bottom/mid/top rail for maximum strength
- Insert lock ring into one end of rail by depressing tabs, insert in rail end and release
- Depress lock ring tabs to insert bottom rail in first post
- Tabs will recoil to hold rail in post
- Insert lock ring in rail end, insert end into third post
- When installing rails leave a 1" gap between rail ends inside post to allow for expansion

5. Support and Secure

- Block up bottom rail to determine correct fence height
- Fill holes around posts with concrete mix
- Tamp, level and square
- Fence assembly may be continued by installing all bottom rails first or one section at a time
- To lower a post, place a wood block from corner to corner of the post and carefully tap with a mallet
- Never strike the PVC post without a wood support

6. Hang Gate/Install Hardware

- For complete details, see gate installation instructions in hardware box
- Position gate between posts
- Allow 1-1/2" gap on hinge side of the gate and 1-1/4" on latch side to allow for the gate swing and hardware
- Block up gate to square with fence; rails should be level
- Gate hardware must be mounted to two sides of the post

7. Solidify Gate Posts

- It is critical that gate hinge and latch posts are solid to ensure proper gate functionality. Two methods are available:
 - A. Aluminum gate post stiffener
 - Slide aluminum gate stiffener inside hinge, latch or end posts
 - Drive a screw through the vinyl into the aluminum stiffener at the bottom of the post
 - Insert post into the ground
 - Fill hole with concrete around outside of post
 - B. Concrete and rebar*
 - Use two pieces of 1/2" rebar in each hinge, latch and end post
 - Rebar should extend from the bottom of the hole to approximately 12" from the top of the post
 - Hold rebar in opposite corners of post with rebar separator clips
 - Fill post with concrete mix to cover rebar and hardware fasteners
 - Tamp post with a rubber mallet to eliminate air pockets
 - Leave gate on blocks for 72 hours to allow concrete to set

8. Install Caps

- Install post caps by pressing in place inside post

Post & Rail with CertaGrain® Texture

Includes: 2-Rail, 3-Rail and 4-Rail

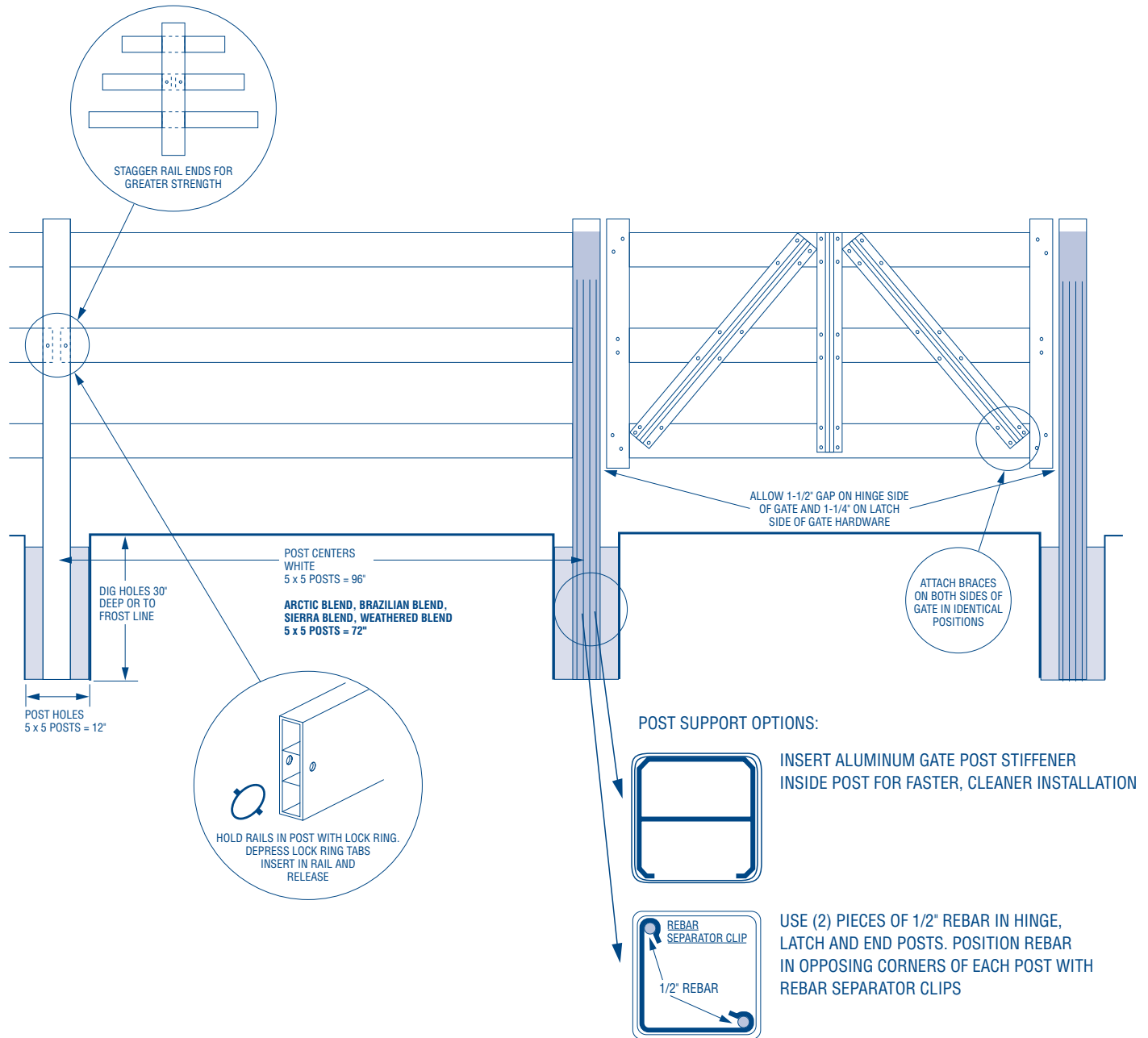

Variable Terrain Installation

Calculate Rise/Foot Angle

To determine the hole enlargement size, first calculate the slope rise/foot or the angle of the slope. Refer to the diagram and examples.

- Measure section length in inches
- Determine section rise by using line level and measuring vertical rise; measure rise in inches
- Divide rise by section length to get rise per inch
- Multiply by 12 to determine rise per foot

Ex: 24" rise ÷ 96" length = .25 rise per inch = 3" rise per foot

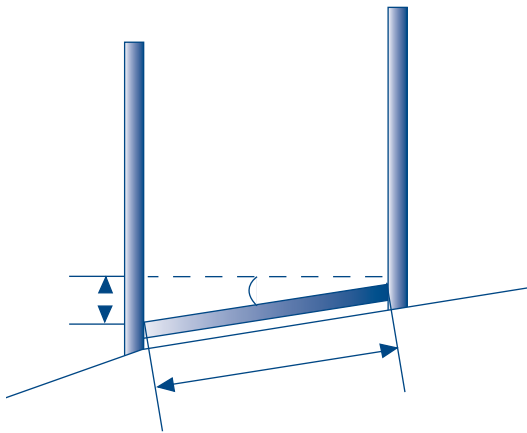

- Two methods exist for installing a fence on variable sloping terrain — stepping and racking
- For either method, divide slope evenly into all sections

Stepping Method

With the stepping method, the rails remain horizontal and the posts are extended to accommodate the variance in terrain. Longer end posts should be used and holes for the opposite side of the post can be field fabricated with template kit and router or spiral saw to accept rails.

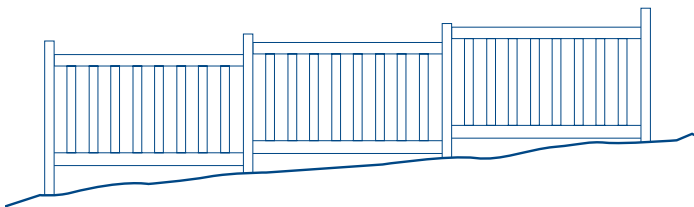

Racking Method — 10° or Less

With the racking method, the horizontal rails will follow the sloping terrain.

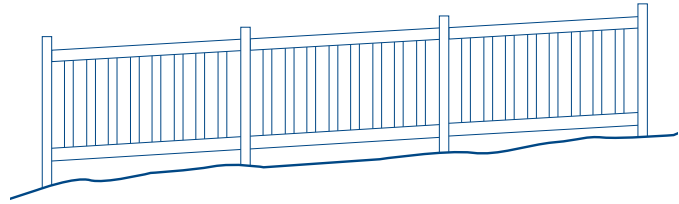

When installing multiple sections, it is advisable to use an end post and field fabricate the opposite side of the post to avoid a jagged fence line.

Depending on the severity of rack (and specific fence style), the following field fabrication steps may be necessary for proper installation:

1. Enlarge holes in post to accept rails
2. Enlarge holes in rail to accept pickets
3. Shorten picket length

NOTE: Depending on severity of rack, post centers may need to be decreased. Be sure to verify prior to setting posts.

1. Enlarge holes in post to accept rails
 - Determine angle or slope
 - Place first post in hole and hold plumb
 - Place rail next to post (not in routed hole) at correct angle of grade

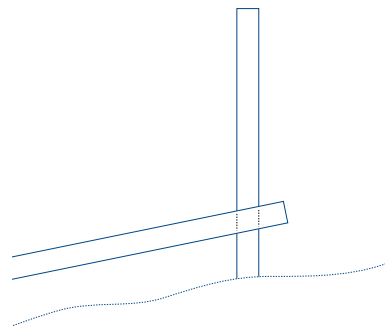

- Mark rail where post crosses it on angle
- Remove rail, measure the length of the drawn angle. Add 1/8" to this length to determine proper post hole size
- Enlarge post holes

NOTE: Always open bottom of top hole and top of bottom hole to maintain proper fence height.

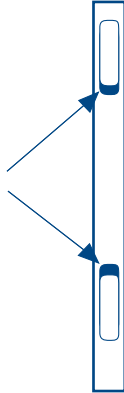

- Holes may be cut utilizing a template kit and router or spiral saw
- Determine location of holes on opposite side of line post by laying post across side of rail (align with routed hole) and marking exit position of rail on opposite side of post
- Cut holes with template kit and router or spiral saw as previous

2. Enlarge holes in rail to accept picket

- Position rail at desired angle
- Hold picket plumb against side of rail
- Mark picket where rail crosses it on angle

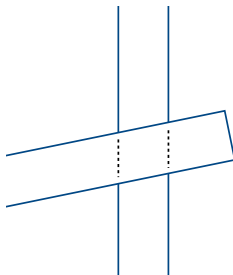

- Measure the length of the drawn angle and add 1/8" to this length to determine proper rail hole size
- Enlarge holes with a spiral saw

NOTE: Always cut the same side of each hole to maintain spacing.

3. Shorten picket length

- For extreme racking situations, picket ends may need to be cut to accommodate rack
- Position top and bottom rails in routed post holes
- Position picket next to rails so it is plumb and aligned with bottom side of bottom rail
- Mark position where top of picket intersects with top of top rail; subtract 3/8" and cut picket to length

NOTE: For ribbed rails, top and bottom of picket will need to be aligned with internal rib.

Post Routing Template Kit

The routing template kit can be used to enlarge holes for racking as well as to create transitions for stepping, changing heights or styles.

Install 3/8" router blade and 5/8" bearing or router guide. Any substitutions may result in improper hole size or damage to the template kit.

NOTE: Template cutout size is designed to be 1/8" larger than the finished cut to allow bearing to follow the shape.

Select the appropriate template for the application.

Assemble the template as shown, configured for the desired post size (4" or 5").

NOTE: It is advisable to practice routing on a scrap piece before attempting actual cut.

Mark location of hole to be routed. Offset template cut by 1/8" to allow for bearing (i.e., if hole is to be located 3" from top of post, position edge of template 2-7/8" from top).

Tighten wing nuts. Place on a flat, firm surface to prevent tipping.

Route hole per manufacturer's recommendations.

ALWAYS WEAR SAFETY GLASSES.

Loosen wing nut and remove template.

For situations that require a larger hole to accommodate racking, route a standard hole, loosen wing nuts and slide template to new position to route excess material.

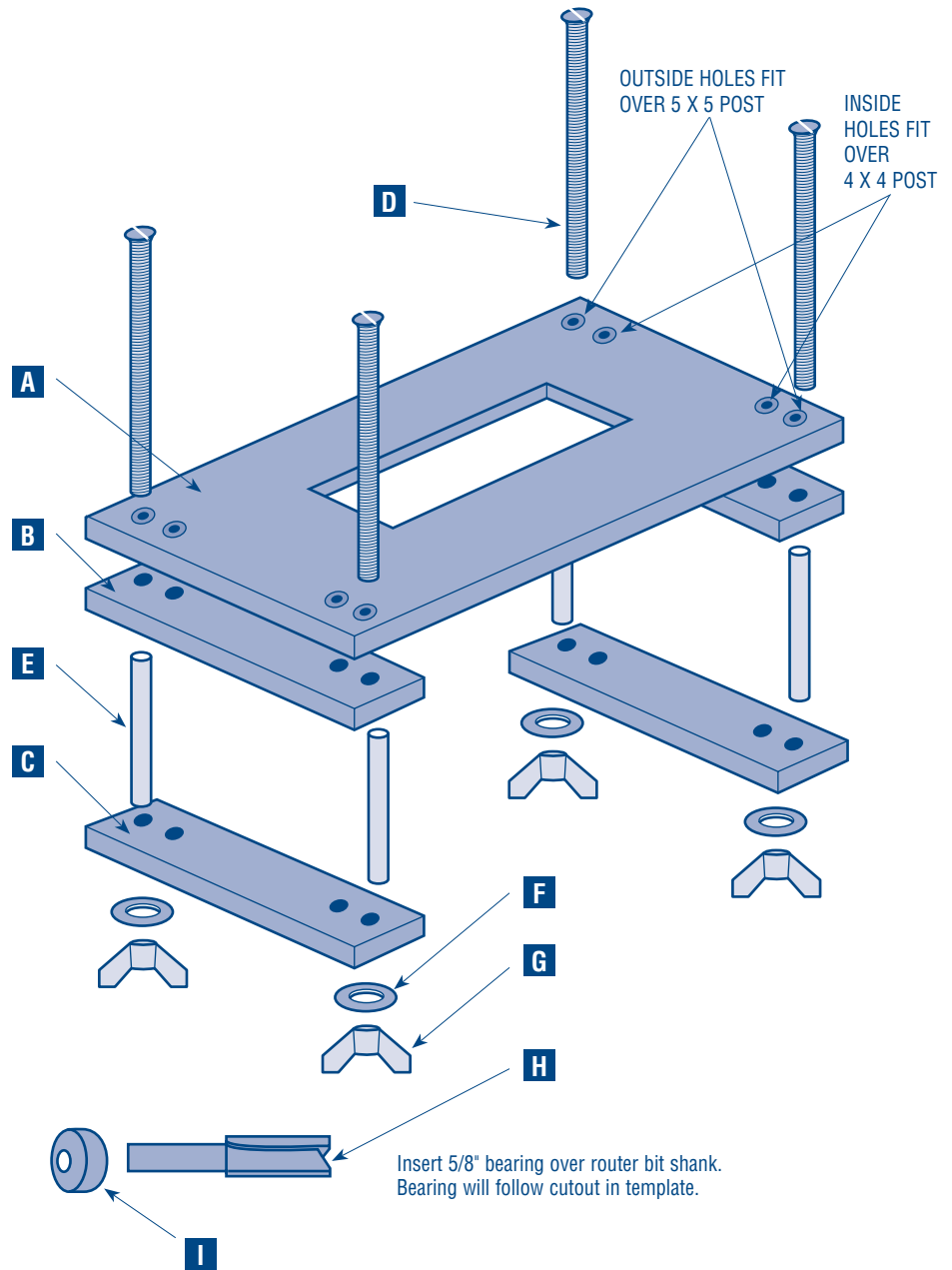

- A** ROUTING TEMPLATE
- B** 1-1/8" TEMPLATE SPACER PLATE
- C** 1-1/2" TEMPLATE SPACER PLATE
- D** 1/4" -20 X 6" BOLTS
- E** 3/8" OD PLEXI TUBE
- F** 1/4" FLAT WASHER
- G** 1/4" -20 WING NUT
- H** 3/8" ROUTER BIT W/ 1/4" SHANK
- I** 5/8" BEARING W/ 1/4" ID OPENING

Glossary

Accent Decorative addition to top of fence such as lattice.

Aluminum Channel Aluminum structural support used as a stiffener in rails.

Auger Hand or machine-operated tool with a screw-like shank for boring holes in soil.

Blocking Method for supporting horizontal members, such as fence rails or gates.

Brace Diagonal component of a gate; provides dimensional stability.

Bullet Clip Gravity clip that is used to hold rails in posts.

Caps Vinyl accessory placed on top of fence posts to provide a finished look and prevent water penetration.

Crimp Lock Method for fastening rails inside posts. The rail is notched (crimped) so that it stays within the post once inserted.

EZ Set Bracket Aluminum bracket system that fits over a steel post as an alternative installation method to secure and hold vinyl post in position.

Fence Layout Section-by-section diagram of the proposed fence line.

Frost Line Lowest level in soil that freezes. Frost line depth depends on winter temperatures, soil type and vegetation cover, and varies from 0" in warm regions to 3' or more in cold-winter areas.

Gate Movable framework or solid structure that swings on hinges; controls entrance or exit through an opening in a fence.

Gate Post Stiffener Structural aluminum support used in gate hinge and latch posts to solidify as an alternative to traditional concrete and rebar method.

Gloss Describes amount of reflection or sheen on the surface of vinyl.

Good Neighbor Fence Fence that has the same look on both sides.

Lock Ring Circular-shaped fastener with tabs that insert into rails for holding into posts.

Opposite Gate Used in double-gate situations; complements the primary gate; diagonal brace is mounted in the opposite direction for a pleasing, symmetrical look.

On Center (O.C.) Measure from the center of one object (e.g., a post) to the center of the next post.

Picket Vertical member of fence between rails.

Post Vertical support member of fence system.

Picket End Channel U-shaped channel attached to the posts on both ends of a privacy fence section.

PVC Polyvinyl chloride, the plastic resin used to manufacture "vinyl" fence.

Rail Horizontal pieces between fence posts.

Racking Method of installing fence on sloped terrain. Fence posts and pickets are plumb, but the rails are mounted at an angle so they parallel the grade.

Rebar Reinforcing bar, placed in end and gate posts to vertically reinforce the fence; No. 4 rebar is 1/2" diameter.

Routing Template A guide used for field routing posts that require hole positions other than standard.

Scalloped Fence style in which the pickets follow a concave pattern high on both ends and low in the middle.

Slope Degree of incline of a hillside; measured in inches of rise per horizontal inches of run (degree of rack).

Snap Cap Decorative plastic cap and washer system used to cover the screw head.

Spacer Bar Wood or like material used to determine infill area between sections or gates (post spacing).

Steel Channel Galvanized steel structural support used as a stiffener in vinyl rails.

Stepping Method of installing fence on sloped terrain. Fence rails remain horizontal, and posts are extended to accommodate the variance in the grade.

Tamp Method of releasing air pockets in concrete by the use of repeated light blows with a mallet on outside of post or piece of lumber in post hole.

Wall Mount Brackets Aluminum bracket system used as an alternative installation method to fasten fence rails directly to walls or other structural surface.

Weep Holes Openings drilled in bottom rails for drainage of water.

ASK ABOUT ALL OF OUR OTHER CERTAINTEED® PRODUCTS AND SYSTEMS:

ROOFING • SIDING • TRIM • DECKING • RAILING • FENCE
GYPSUM • CEILINGS • INSULATION

www.certainteed.com <http://blog.certainteed.com>

CertainTeed Corporation
P.O. Box 860
Valley Forge, PA 19482

Professional: 800-233-8990
Consumer: 800-782-8777

© 03/15 CertainTeed Corporation, Printed in the U.S.A.
Code No. 40-40-70743

